



TREATMENT TABLE WITH PAPER DISPENSER



ASSEMBLY INSTRUCTIONS

MODEL #996-01-BLK

STEP 1



Please remove all packaging from the table, the table should now look as follows

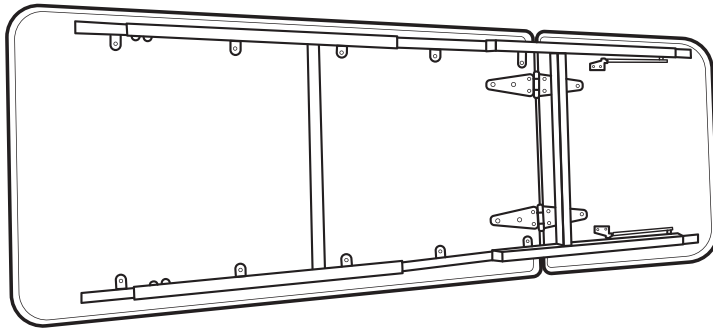

STEP 2



Lift Up all 4 legs, insert 2 Screws for each leg, tighten securely.

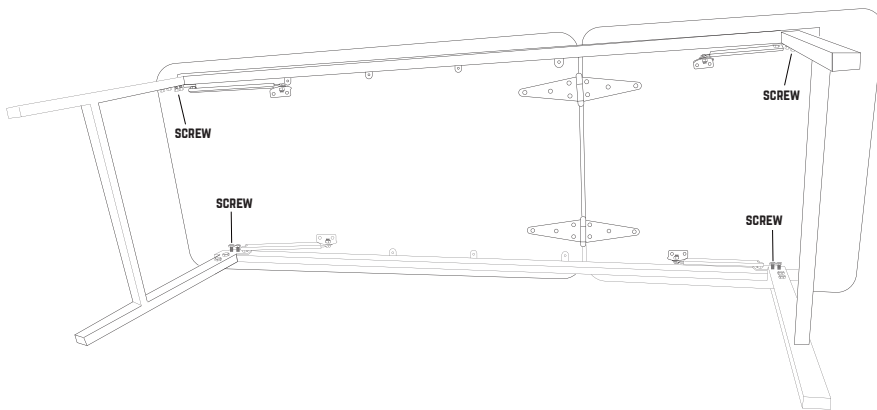

STEP 3



Attached the Crossbar to the Side bars, with the 2 Screws from the Side (as seen in the bellow picture)

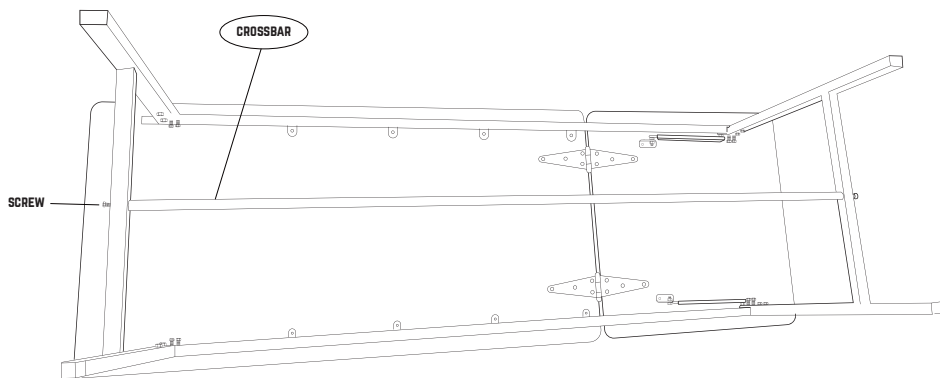

STEP 4



Insert the Paper Dispenser Rack

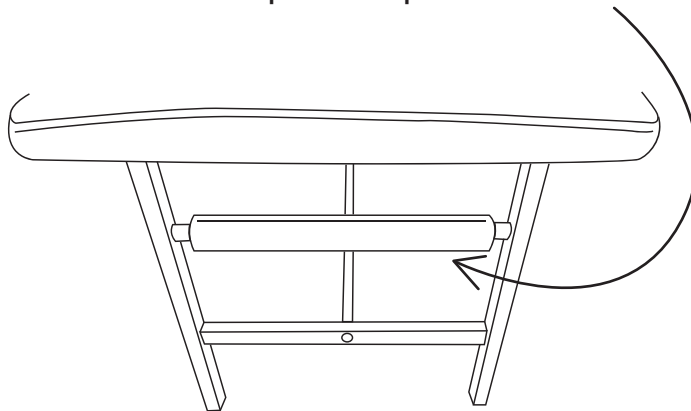



follow us on

