

Ez2 Assembly Instructions

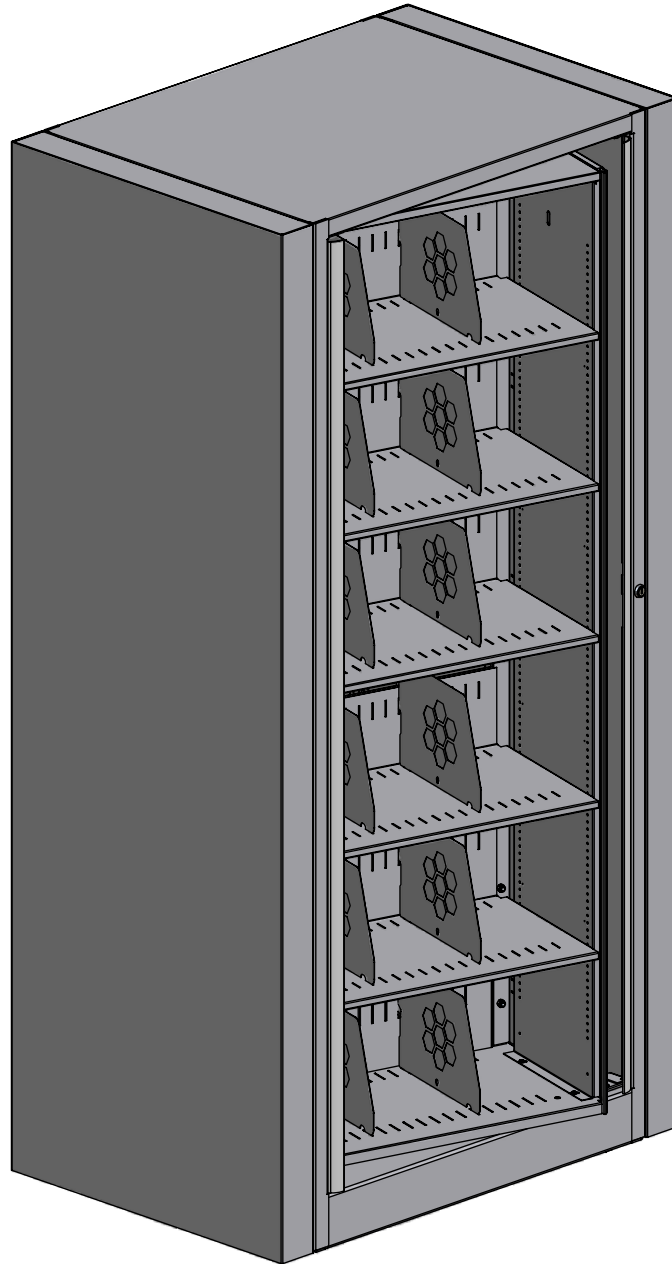

If you need assembly assistance, please contact Customer Service at:
1-866-217-0330 (Monday thru Friday 8:00 A.M. - 5:00 P.M. E.S.T.)

Ez2 Assembly Instructions

(Tube of Thread Adhesive
Not Shown)

Included Hardware:
(Full Scale)

1/4-20 x 3/4"
Countersink Allen
Flat Head Screw

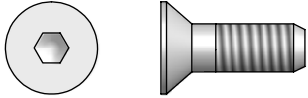

1/4-20 x 1/2" Phillips
Pan Head Screw

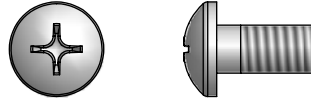

1/4-20 x 5/8" Phillips
Pan Head Screw

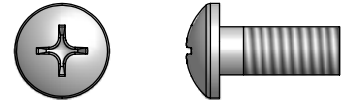

1/4-20 Nylock Nut



#8 x 1/2" Phillips
Pan Head Screw



#10 x 3/8" Phillips
Pan Head Screw



3/16 x 3/8" Allen
Head Cap Shoulder
Screw



#10-24 x 1/2"
Type 'F' Phillips
Pan Head Screw



1/4-20 Flanged
Hex Nut

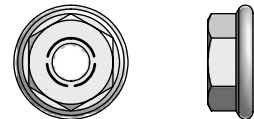

1/4-20 Tinnerman
Nut

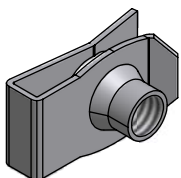

3/32" Allen Wrench
(Not Shown Full Size)



5/32" Allen Wrench
(Not Shown Full Size)



1/4 Diameter
Spacer



Ez2 Assembly Instructions

Parts

Base Assembly

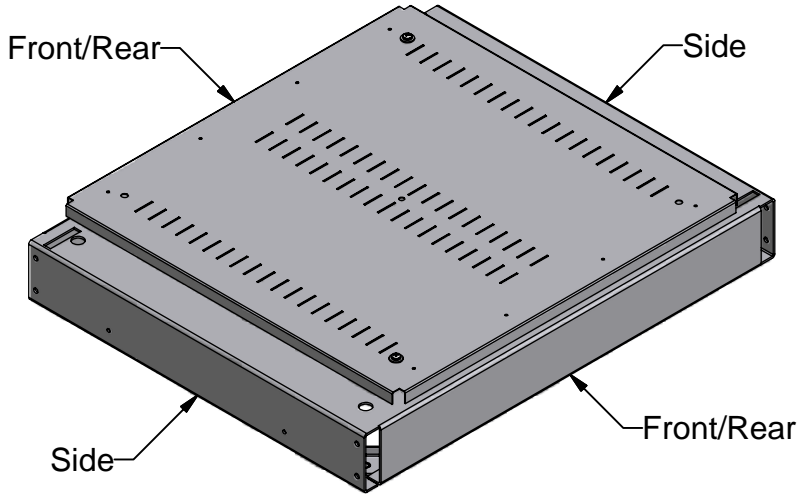

Top Cover of Rotating Cabinet

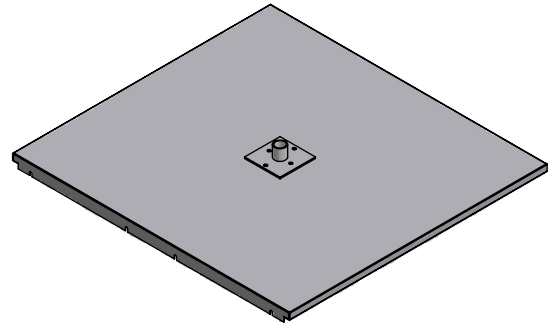

Left Upright
(Qty 2)



Right Upright
w/Lock Plug

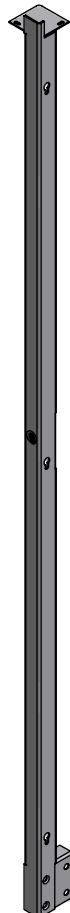

Right Upright
w/Lock

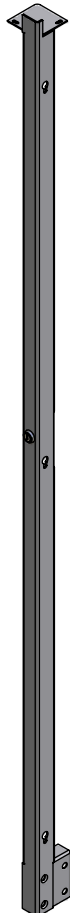

Side Panel
(Qty 2)

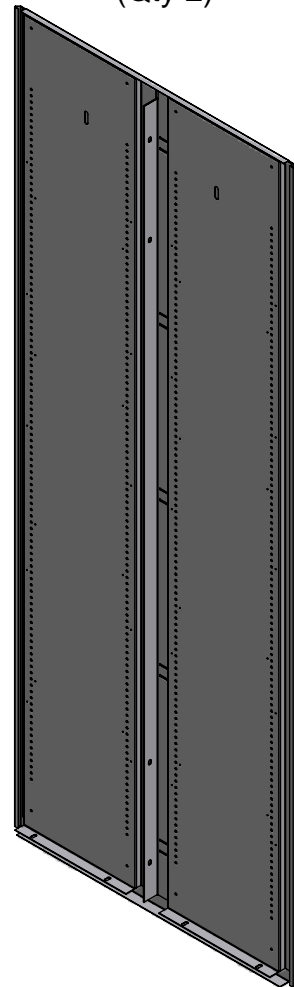

Ez2 Assembly Instructions

Parts

Top Cover

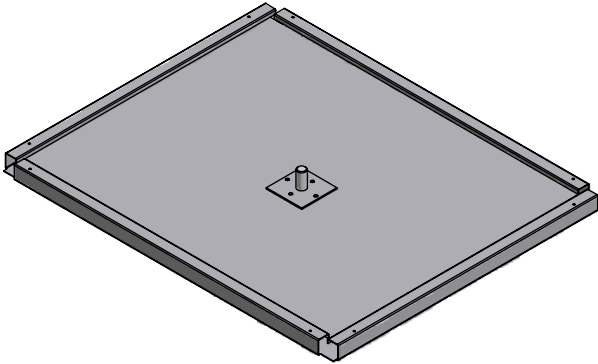

Shelf

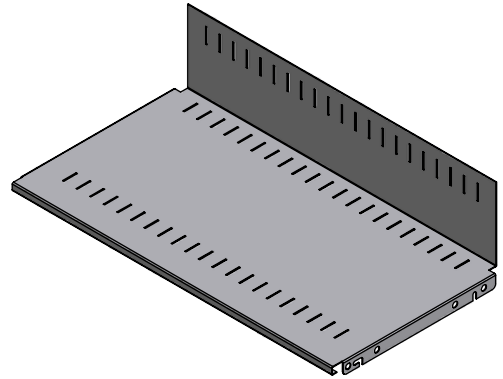

Edge Guard
(Qty 4)



Divider

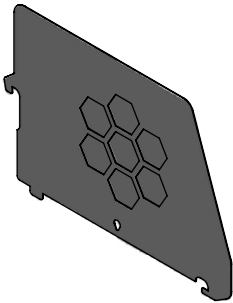

End Panel
(Optional)

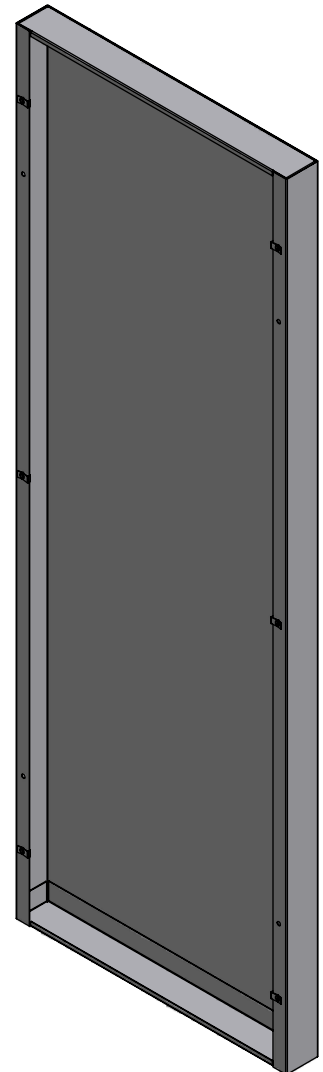

Cabinet Divider

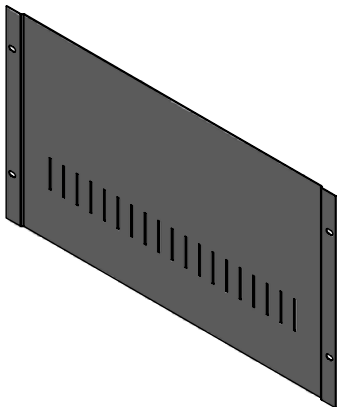

Ez2 Assembly Instructions

Figure A

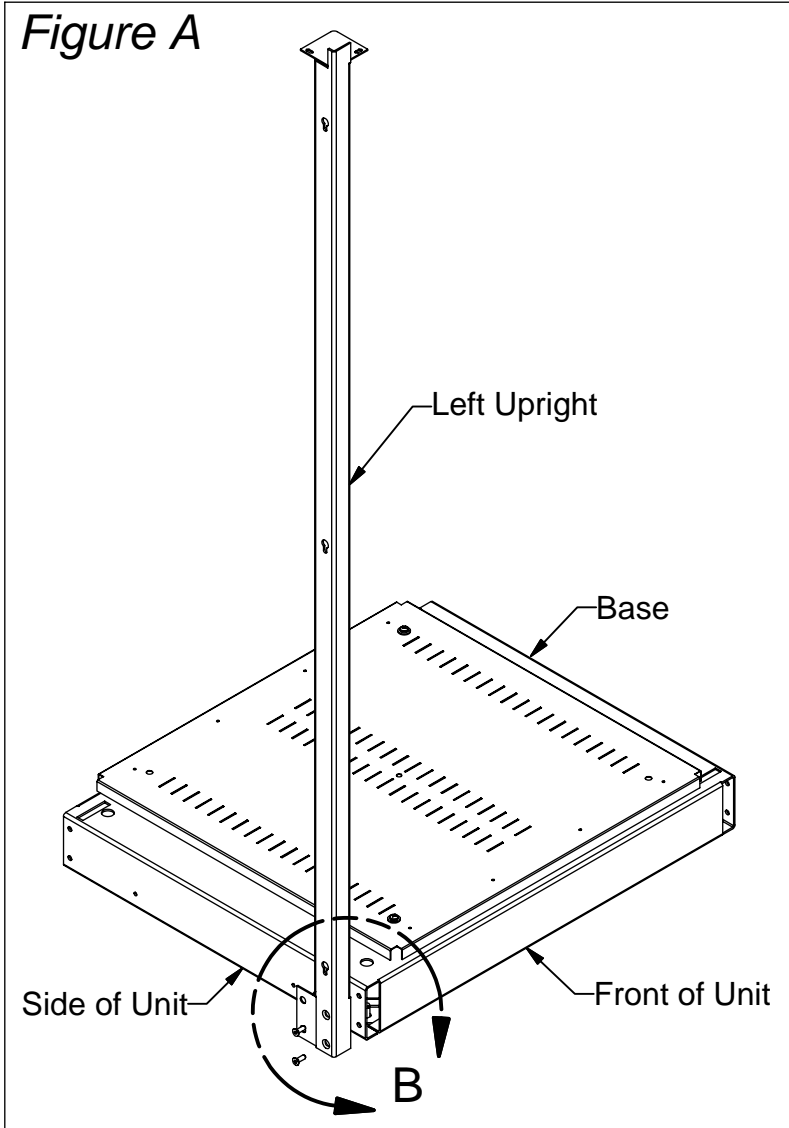

Step 1: Using provided 5/32" allen wrench, attach a left upright to the base with two 1/4-20 x 3/4 Flat Countersink Allen Cap Screws (see *Figure A* and *Detail B*).

Detail B

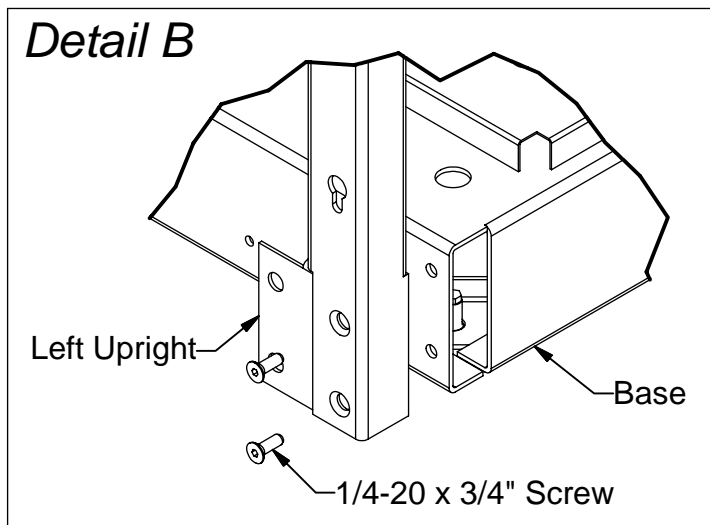

Ez2 Assembly Instructions

Figure C

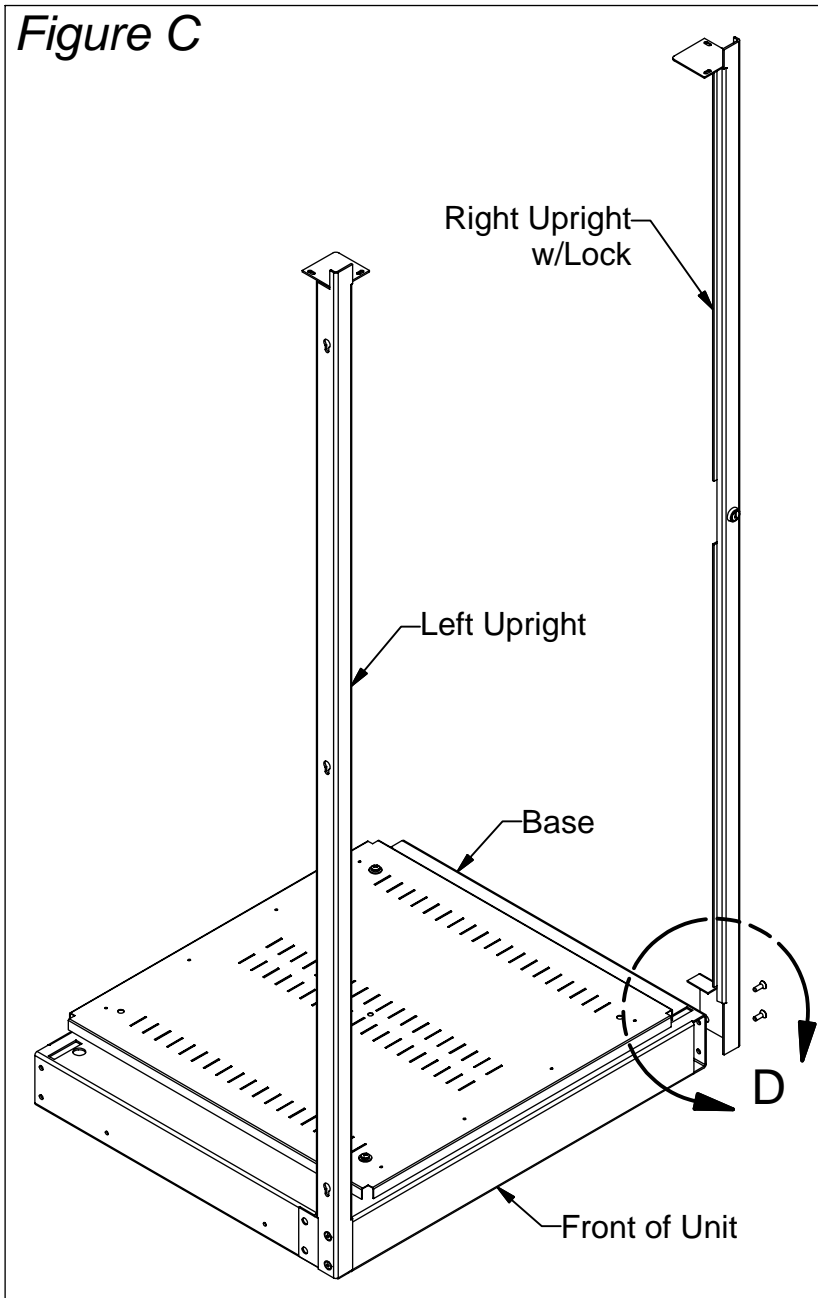

Step 2: Attach right upright with lock to base with two 1/4-20 x 3/4 Flat Countersink Allen Cap Screws (see Figure C and Detail D).

Step 3: Repeat Steps 1 & 2 for the rear of the unit. Use right upright with lock plug for rear of unit. The unit should now look like Figure E.

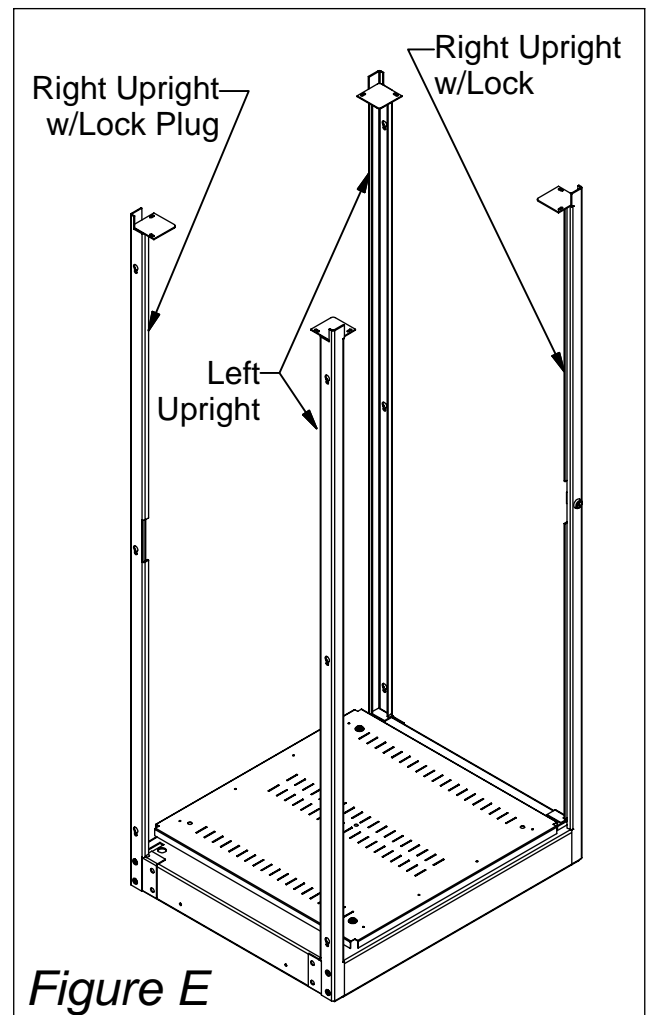
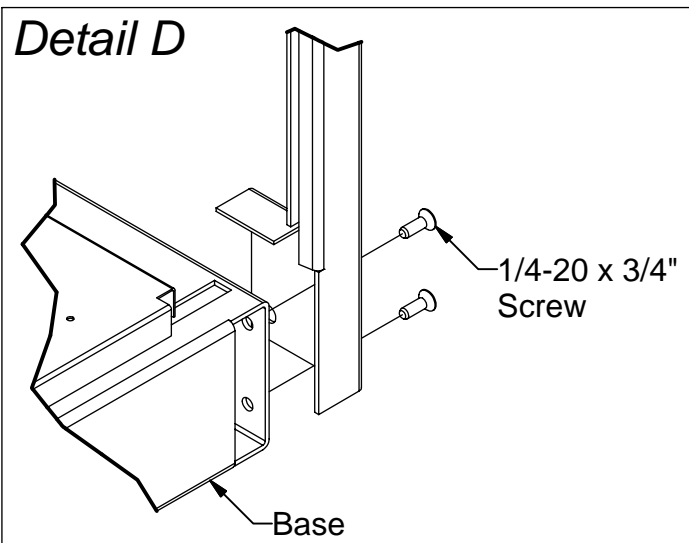
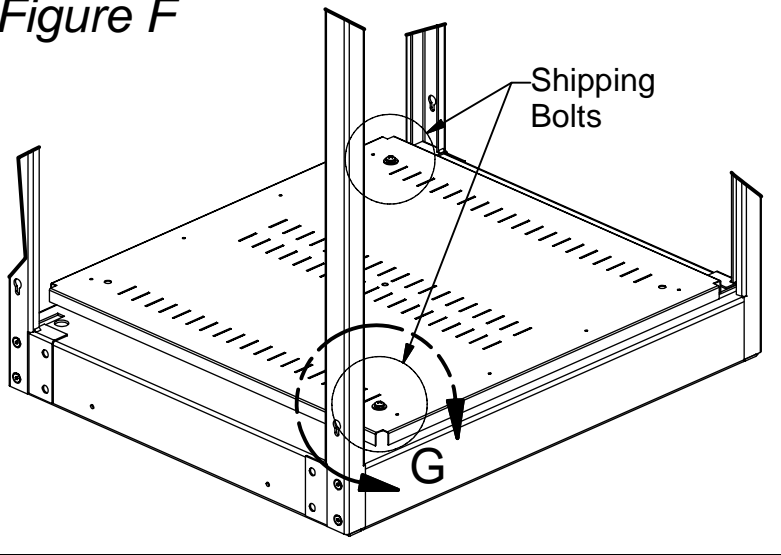

Figure E

Ez2 Assembly Instructions

Figure F



Step 4: Remove two shipping bolts from top of base with a Phillips Head Screwdriver (see *Figure F* and *Detail G*).

CAUTION:

After removing shipping bolts, be careful not to tilt unit as bearings may become dislodged.

Detail G

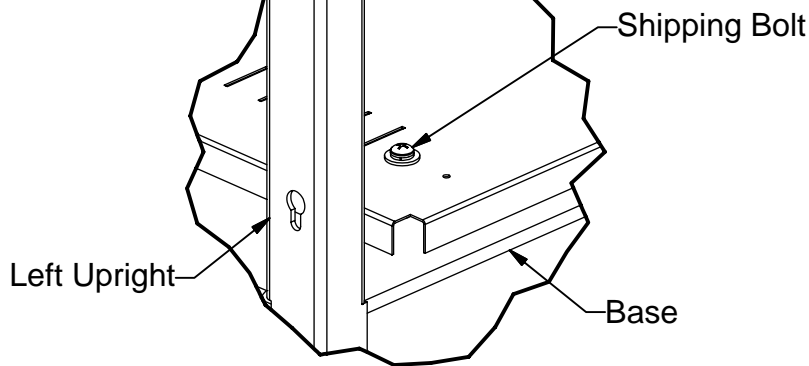

Step 5: Rotate spinning base 1/4 turn and position lock bar as shown in *Figure H* and *Detail J*. Insert hook end of lock bar into rectangular slot (*Detail J*). Rotate lock bar so it is in a vertical position (*Detail K*). Maneuver lock bar until short end of hook protrudes through return hole in base (*Detail K*).

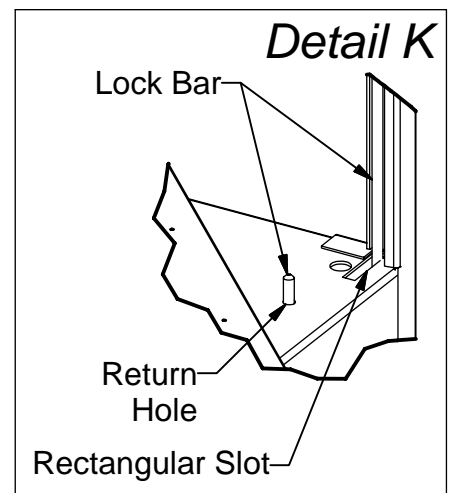
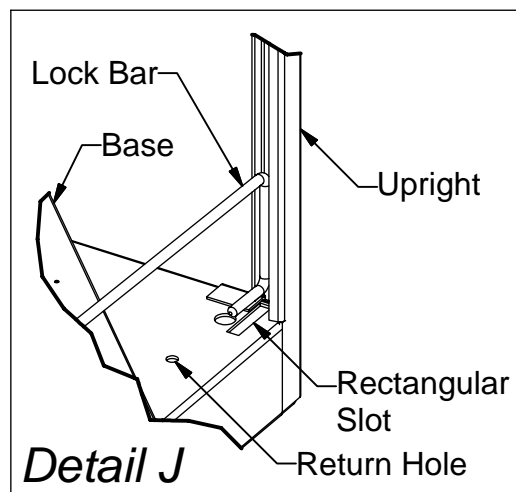
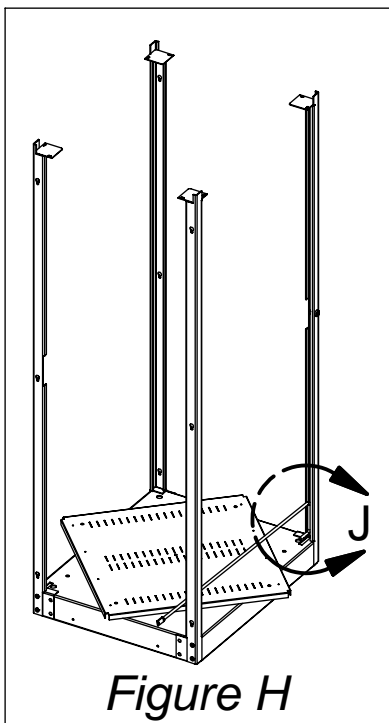

Ez2 Assembly Instructions

Figure L

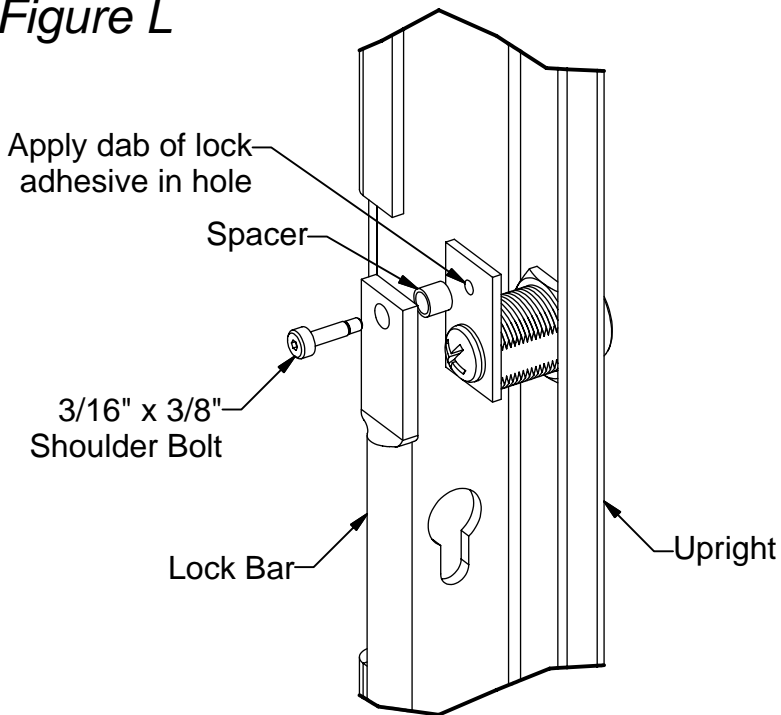

Step 6: Apply a dab of lock adhesive in cam hole. Push one 3/8" shoulder bolt through lock bar and spacer tube, attach to lock cam. Tighten with 3/32" allen wrench supplied.

Figure M

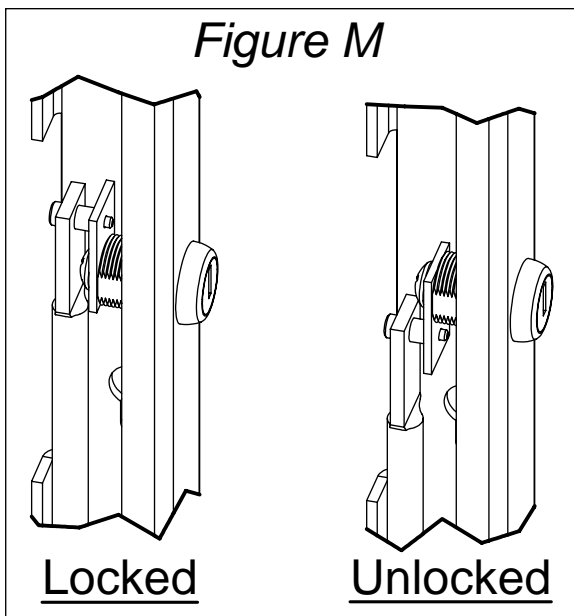

Step 7: Please verify correct positioning of lock components when locked and unlocked (*Figure M*).

Ez2 Assembly Instructions

Figure N

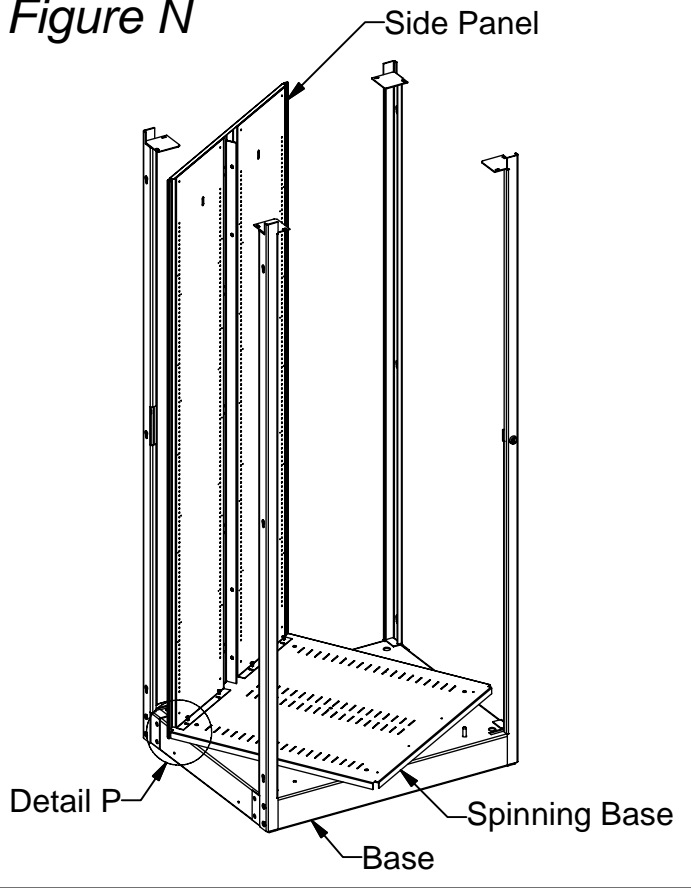

Step 8: Attach first side panel with four #10 x 3/8" Phillips Pan Head Screws. The side panel will fit onto the spinning base as shown in *Figure N* and *Detail P*. ATTENTION: Support side panel so it does not tip over and damage unit.

Figure R

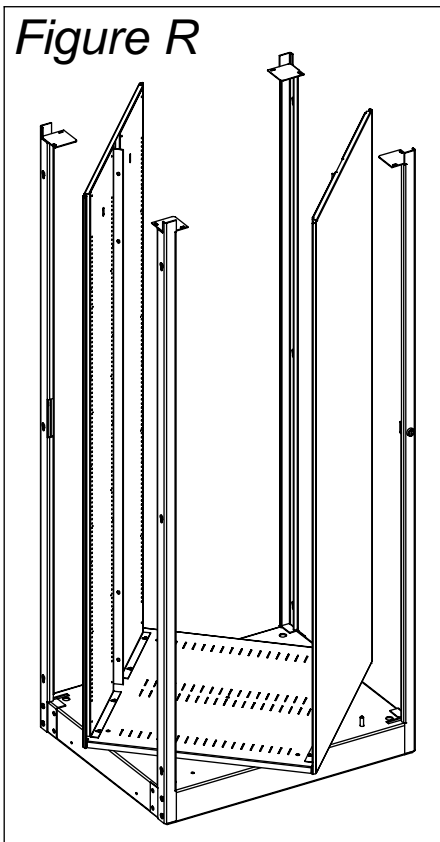

Detail P

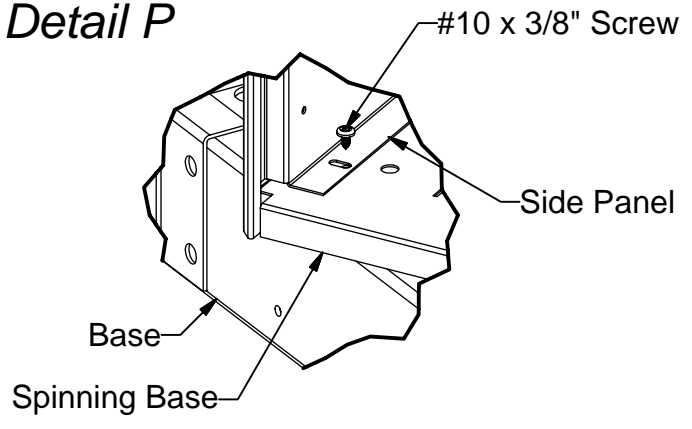

Step 9: Repeat Step 9 for second side panel installation (*Figure R*).

Ez2 Assembly Instructions

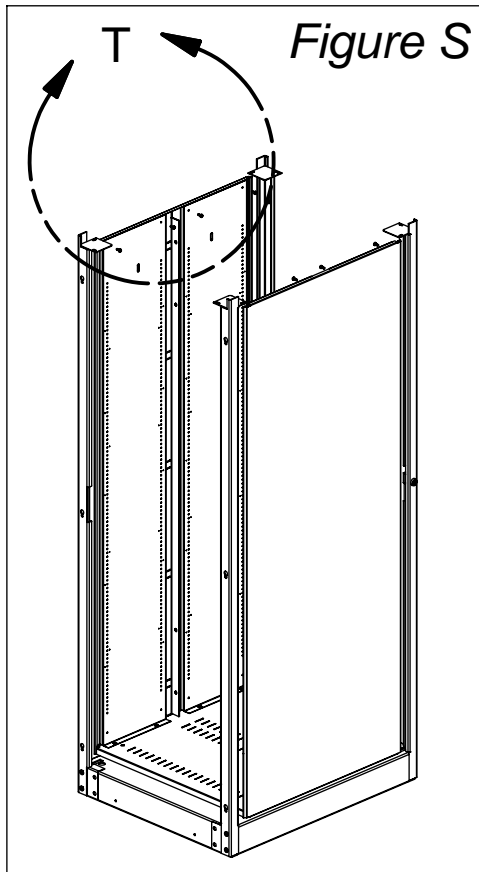

Step 10: DO NOT TIGHTEN SCREWS DURING THIS STEP!!! (Leave an 1/8" gap between head of screw and surface of metal) Fasten four #10-24 x 1/2" Type 'F' Phillips Pan Head Screws to each side panel as shown in *Figure S* and *Detail T*.

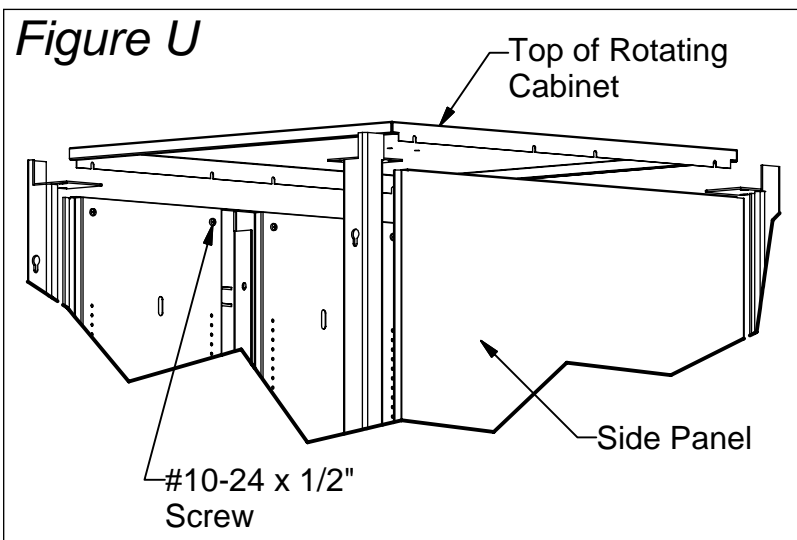
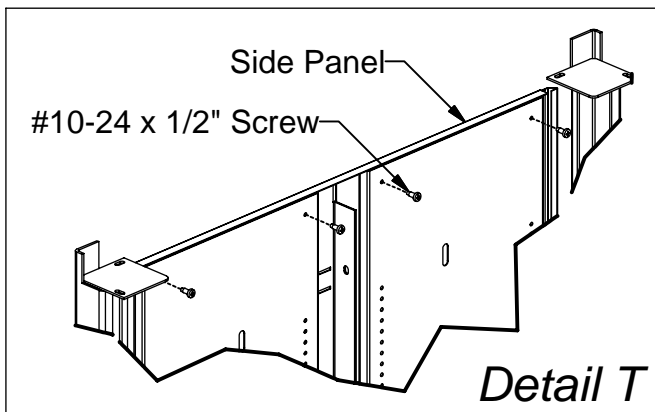

Step 11: Position top of rotating cabinet as shown in *Figure U* with slots aligned with the screws that were just installed. Now tighten the screws.

Ez2 Assembly Instructions

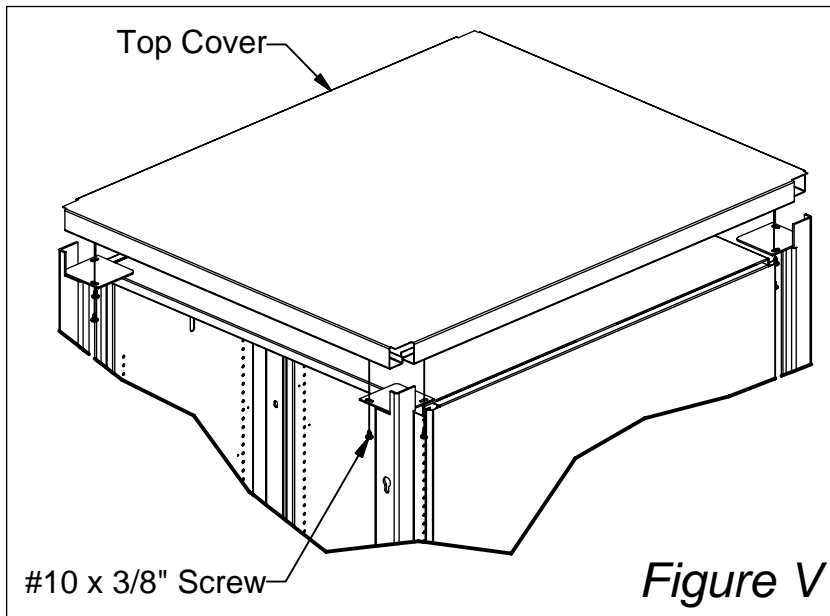

Step 12: Position top cover as shown in *Figure V*. Make sure that shaft on top cover goes into hub on top of rotating section. Fasten top cover to uprights with a total of eight #10 x 3/8" Phillips Pan Head Screws.

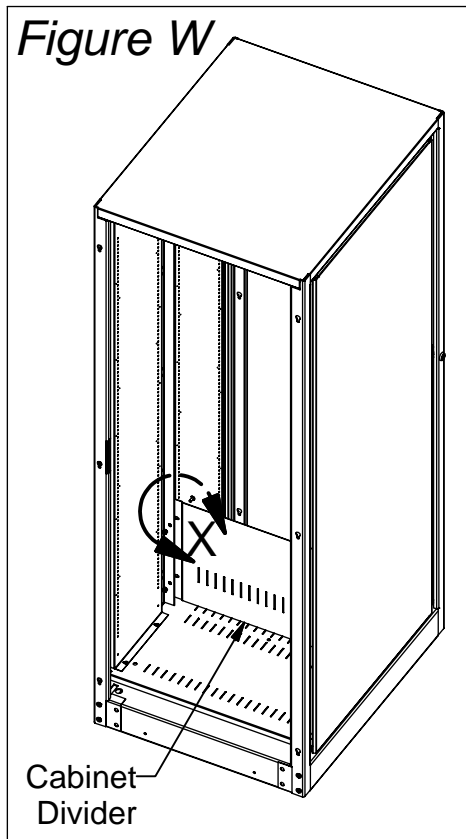

Step 13: Position and attach cabinet divider using four 1/4-20 x 1/2" Phillips Pan Head Screws and 1/4-20 Nylock Nuts (*Figure W* and *Detail X*).

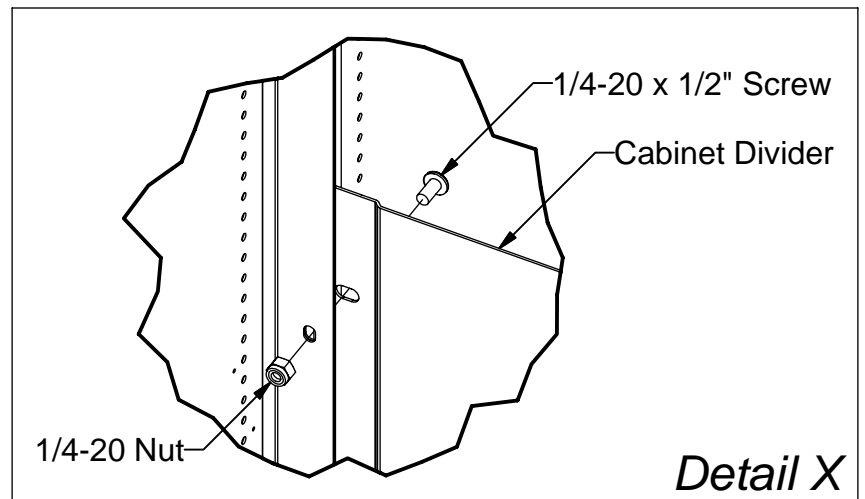

Ez2 Assembly Instructions

Figure Y

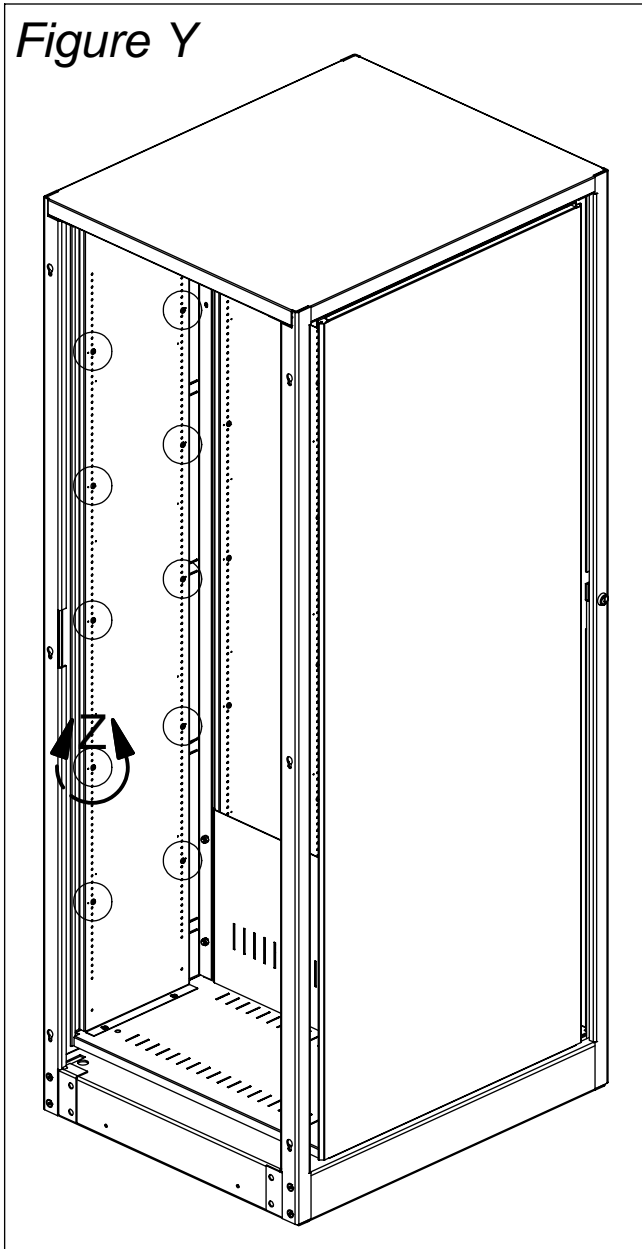

NOTE:

For standard filing applications, a small indicator hole can be found next to each standard shelf hole (see *Detail Z*). This will allow for equal shelf openings and in most cases, it will leave enough space for a posting shelf. Leave about an 1/8" gap between head of screw and surface of side panel when fastening screws in next step.

Step 14: Fasten four #10-24 x 1/2" Type 'F' Phillips Pan Head Screws at locations indicated in *Figure Y* for each shelf that will be installed.

Detail Z

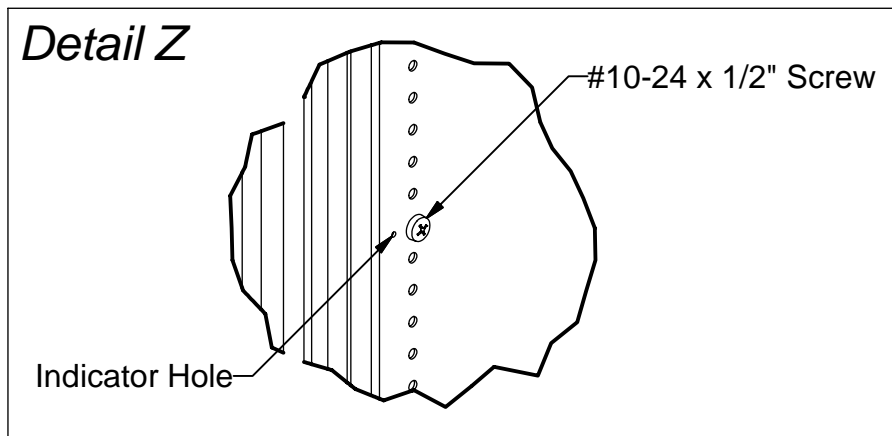

Ez2 Assembly Instructions

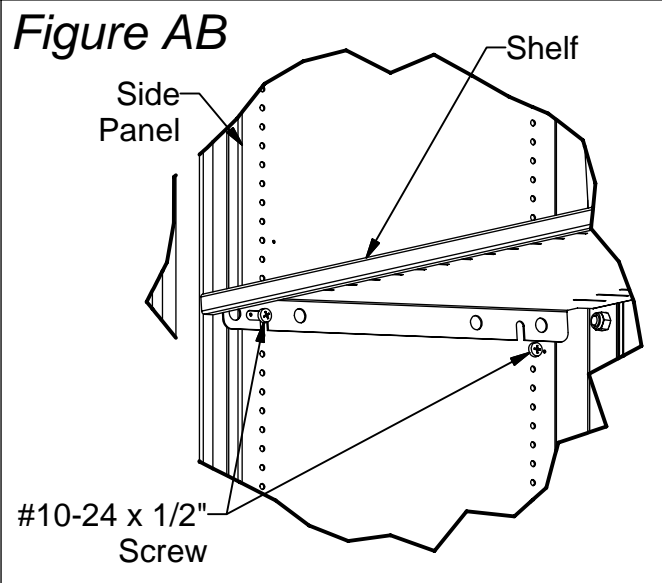
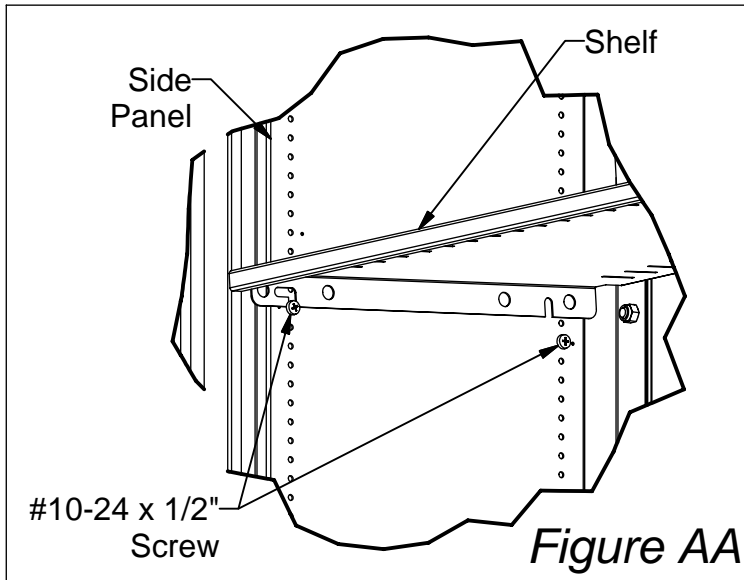

Step 15: To install shelf, position shelf so it hooks on to front two mounting screws (*Figures AA & AB*), then push shelf in and tip it down so rear of shelf hooks on to rear two screws (*Figure AC*). Tighten screws.

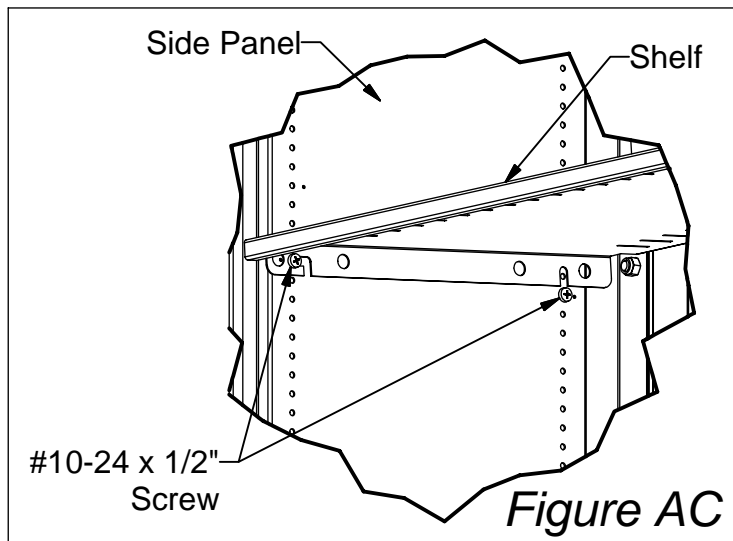

Step 16: Repeat Step 15 to install remainder of shelves.

Ez2 Assembly Instructions

Figure AD

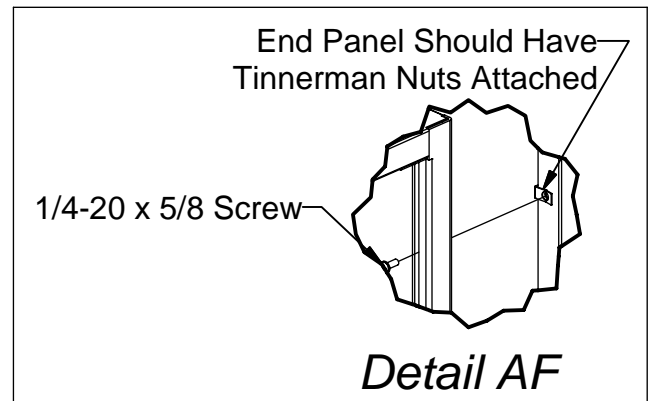
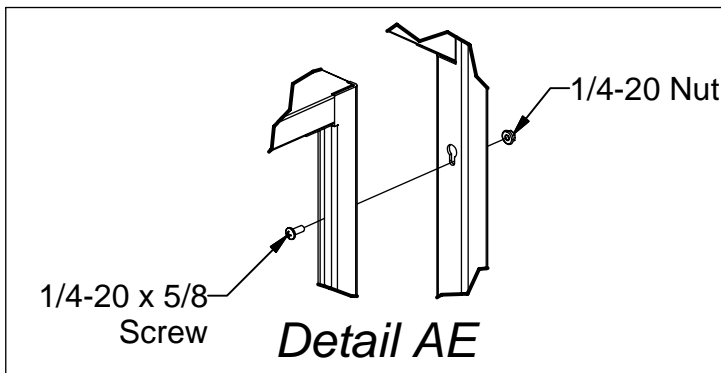
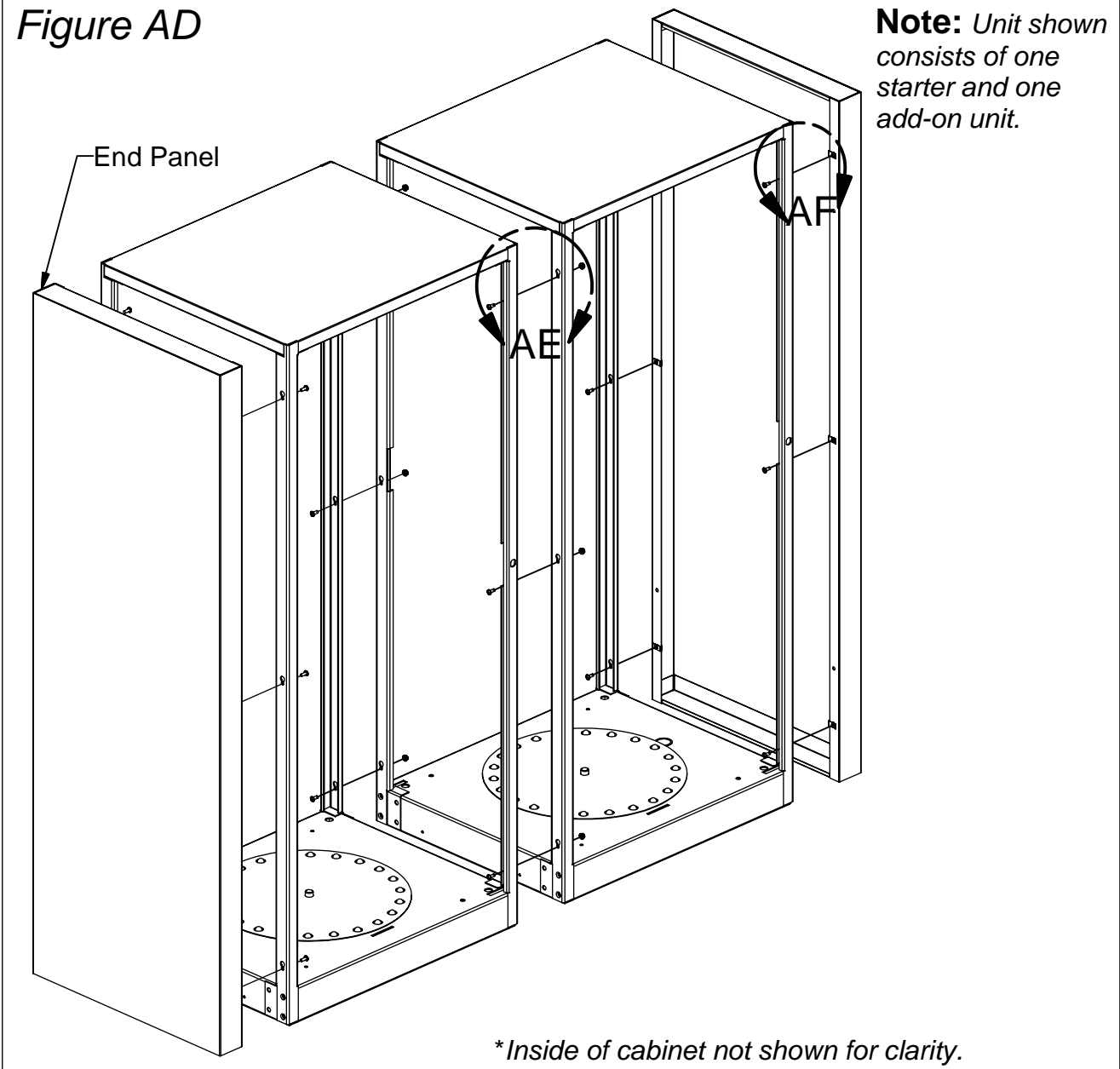

Step 17: Units will attach to each other by using six 1/4-20 x 5/8 Phillips Pan Head Screws and Nuts (see *Figure AD* and *Detail AE*). Units attaching to an end panel will use six 1/4-20 x 5/8 Phillips Pan Head Screws (see *Figure AD* and *Detail AF*).

Ez2 Assembly Instructions

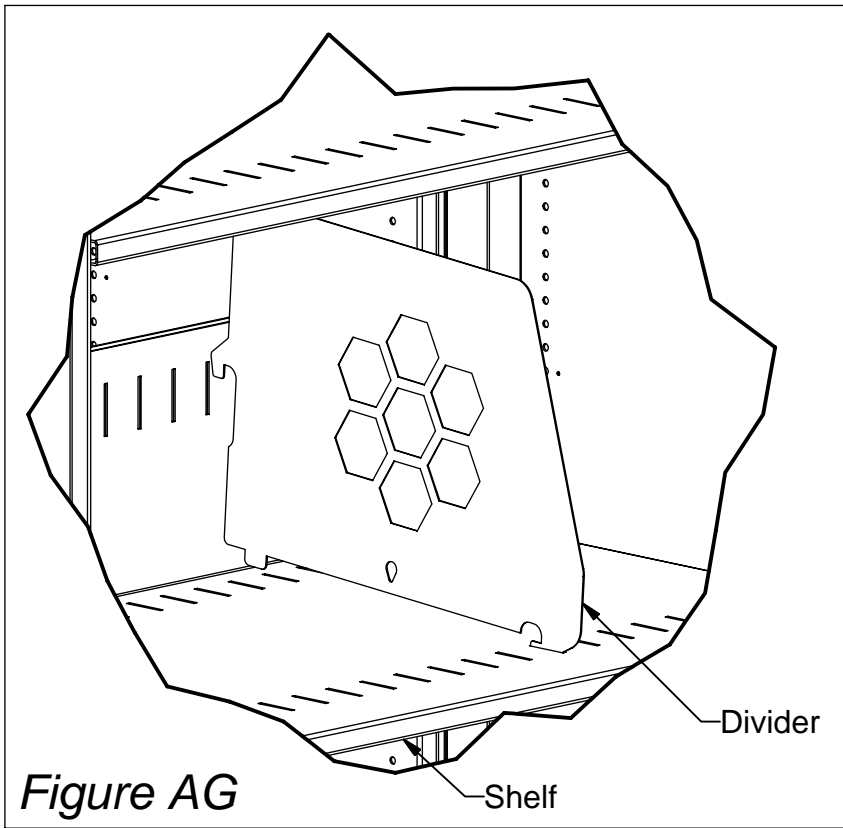

Step 18: To install dividers, insert front tab first (*Figure AG*). Then insert rear two tabs (*Figures AH*). Two dividers per shelf.

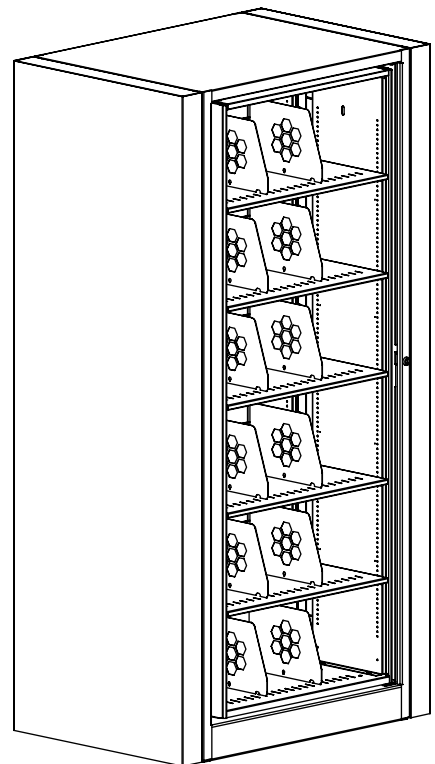
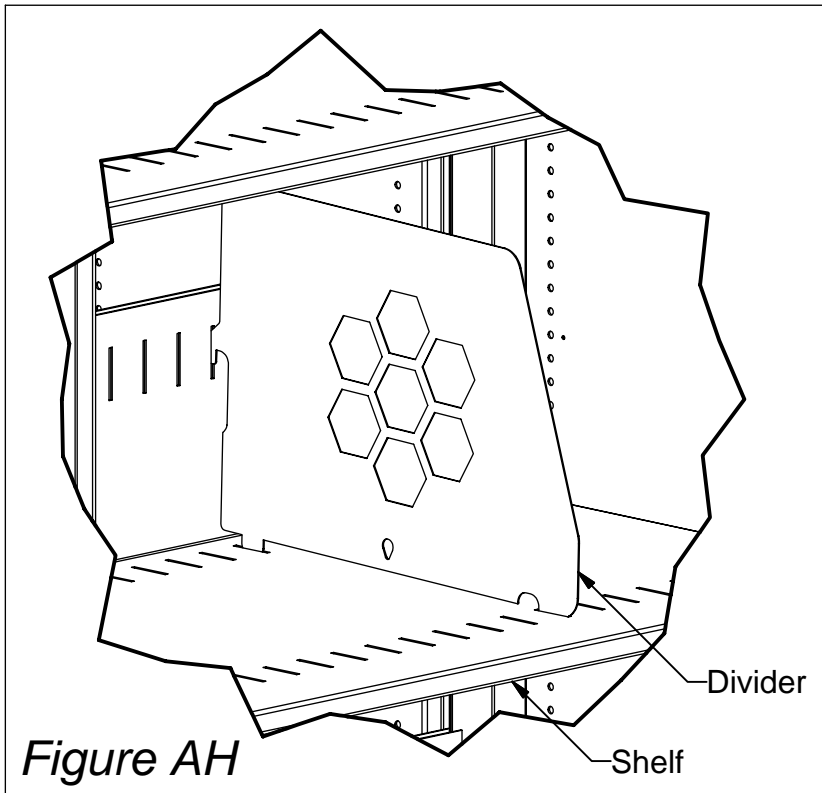

Ez2 Assembly Instructions

Figure AJ

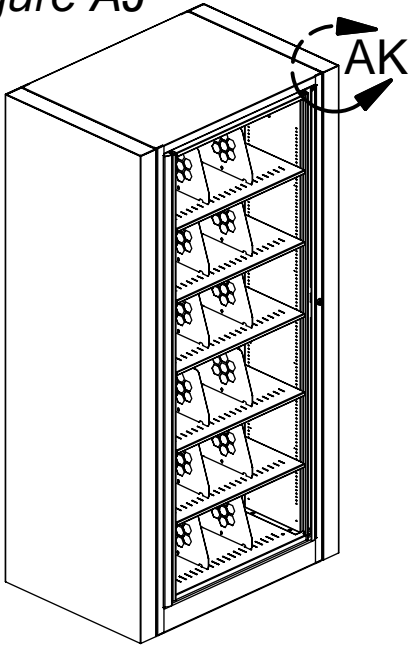

Step 19: Attach edge guards to the four uprights. Edge guards attach by simply pressing them on short flange of each upright (*Detail AK*).

Detail AK

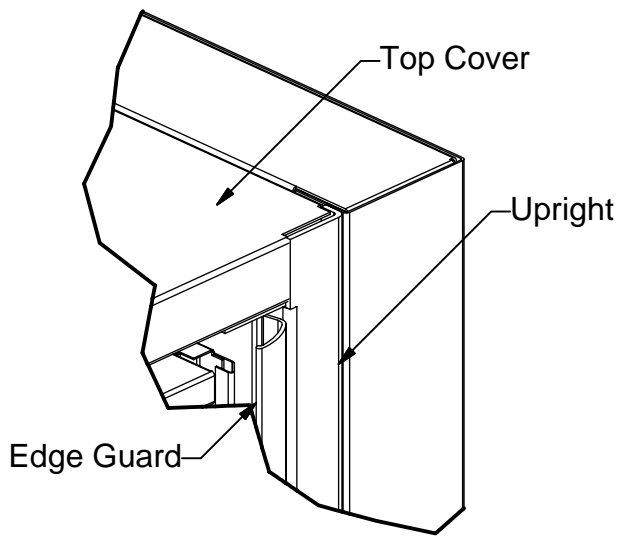
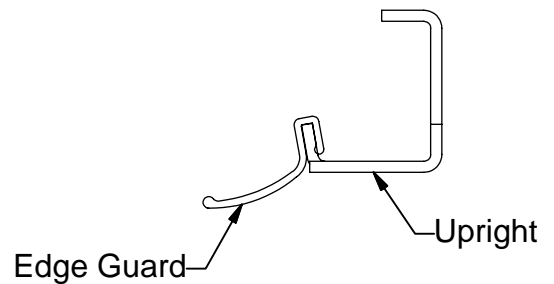

Figure AL



Top View of Upright

Ez2 Assembly Instructions

Figure AM

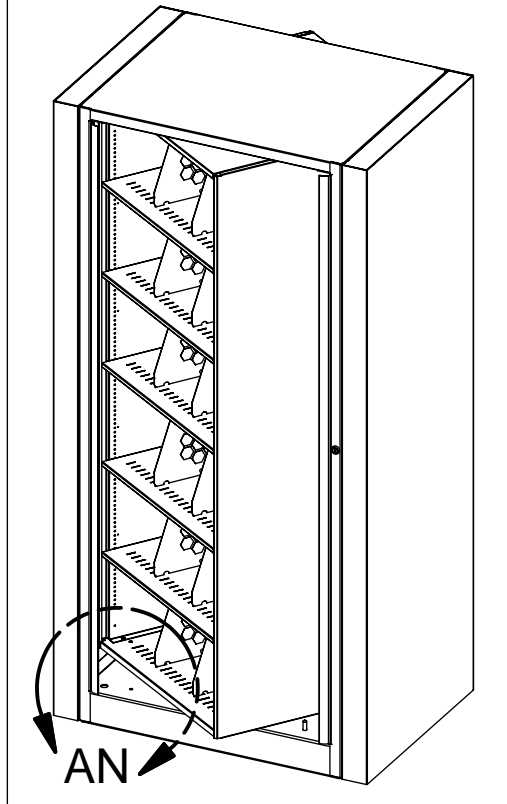

Detail AN

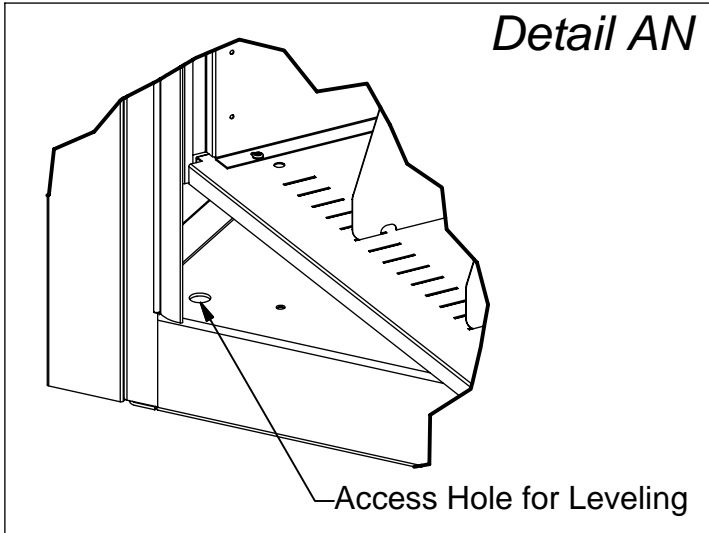

Step 20: To level the unit, use a 3/16" Nut Driver to adjust the four leveling glides from the access holes in top of base (see *Detail AN*).