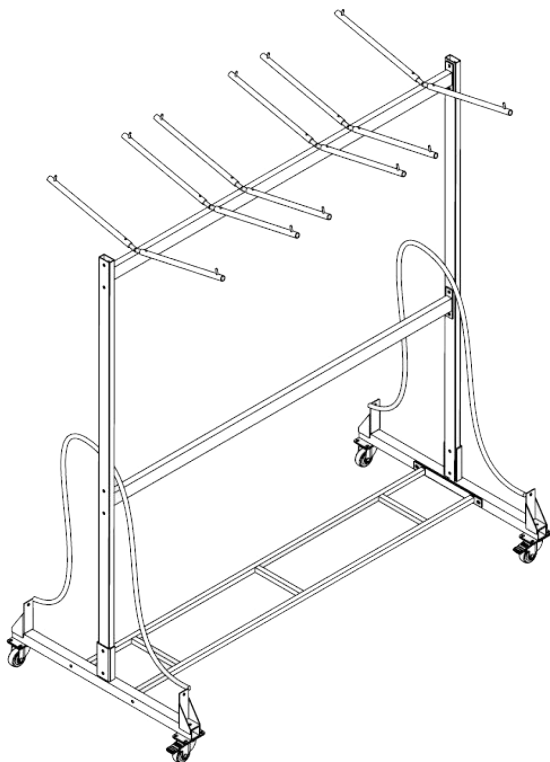


.....

CHAIR AND TABLE COMBO CART

.....



USER GUIDE

ADI690-01



Thank you for your purchase.

.....

**AdirOffice maintains a strong
practice of ongoing development
of products and commercial
research.**

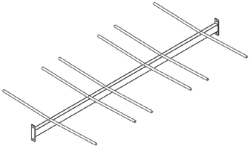
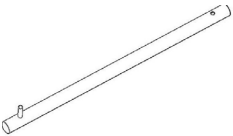
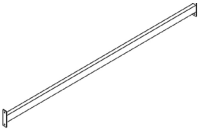
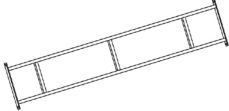
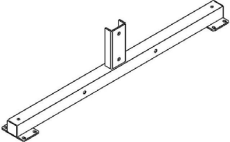

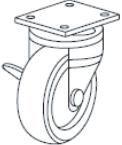
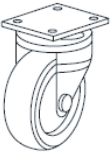
.....

We understand starting and maintaining a business is expensive enough. We can help you make it cost effective and beautiful. Plus, our expert team makes sure everything you need works as efficiently as possible.


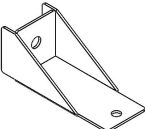
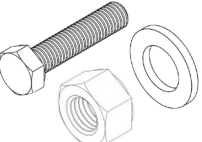
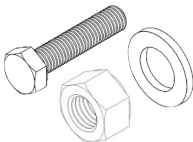
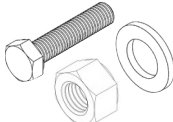

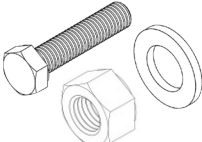
Table of Contents

- 2 Parts List
- 3 Hardware List
- 4 Components
- 5 Assembly Instructions
- 7 Using the Cart
- 8 Care and Maintenance
- 9 Limited Warranty

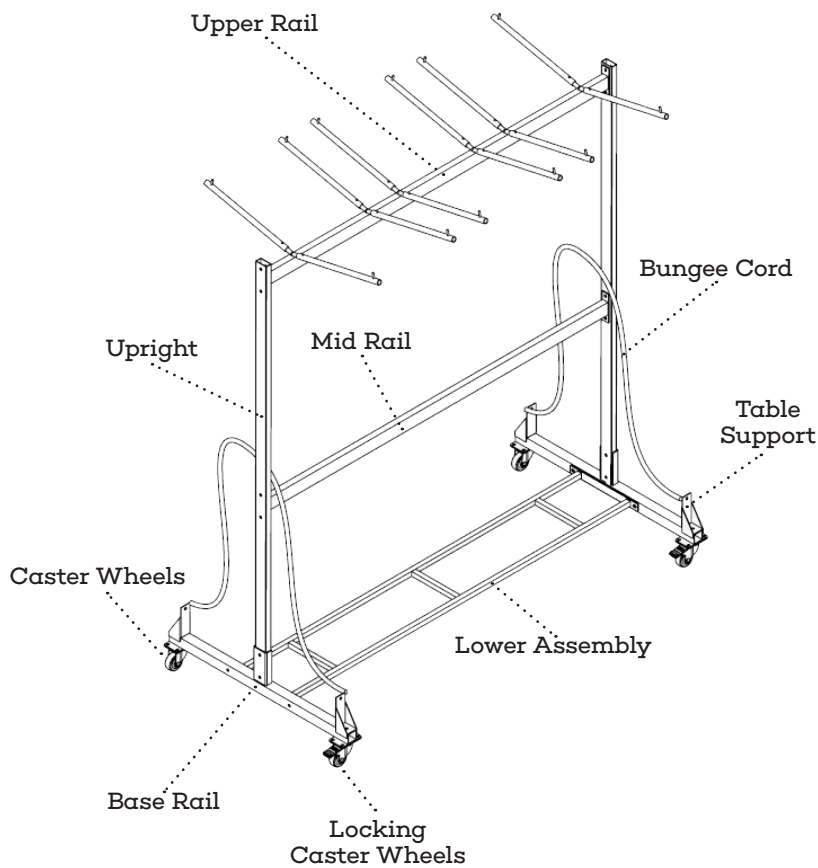
Parts List

<p>A</p>  <p>Upper Rail</p>	<p>B</p>  <p>Chair Hanger (x12) (Preassembled)</p>	<p>C</p>  <p>Mid Rail</p>
<p>D</p>  <p>Lower Assembly</p>	<p>E</p>  <p>Base Rail (x2)</p>	<p>F</p>  <p>Upright (x2)</p>
<p>G</p>  <p>Locking Caster Wheels (x2)</p>	<p>H</p>  <p>Caster Wheels (x2)</p>	

Hardware List

<p>1</p>  <p>Bungee Cord (x2)</p>	<p>2</p>  <p>Table Support (x4)</p>	<p>3</p>  <p>M10 x 50mm Bolt, Washer, & Nut (x12)</p>
<p>4</p>  <p>M8 x 16mm Bolt, Washer, & Nut (x16)</p>	<p>5</p>  <p>M6 x 25mm Bolt, Washer, & Nut (x12) (For Chair Hangers)</p>	<p>6</p>  <p>Wrench (x2)</p>
<p>7</p>  <p>M10 x 60mm Bolt, Washer, & Nut (x4)</p>		

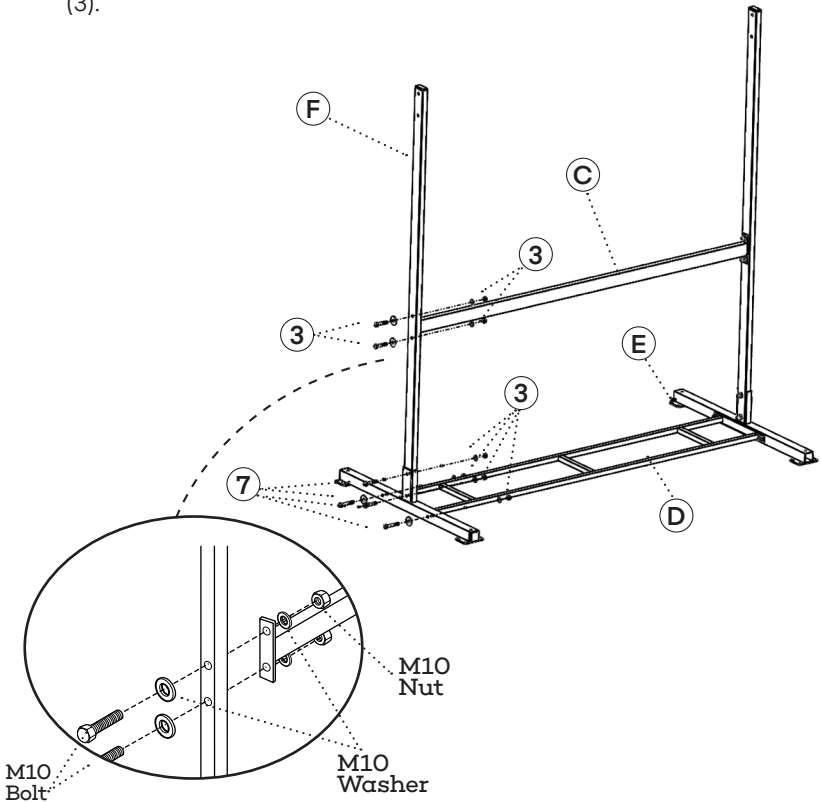
Components



Assembly Instructions

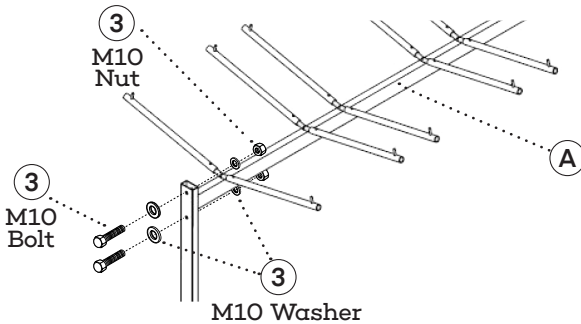
Step 1:

- A.** Align the Upright (F) rail with the Base Rail (E).
- a.** Connect them by using four M10 x 50mm Bolts, Nuts and Washers (3), and secure in place with the included Wrench (6).
- B.** Align the Lower Assembly (D) with the Base Rail (E) and Upright (F) rail.
- a.** Connect them by using four M10 x 60mm Bolts, Nuts and Washers (7).
- C.** Align the Mid-Rail (C) with Upright (F) rail, as pictured.
- a.** Connect them by using four M10 x 50mm Bolts, Nuts and Washers (3).



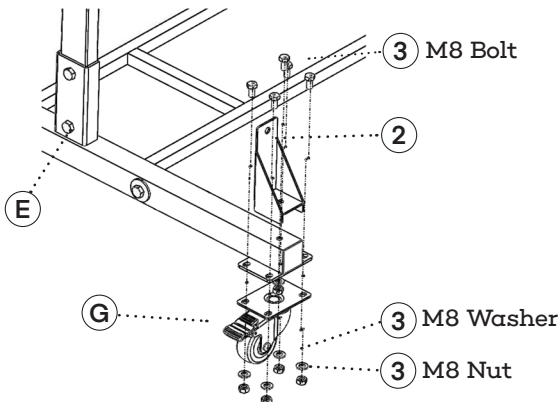
Step 2:

- A.** Align the holes on each end of Upper Rail (A) with the two holes on each Upright (F).
- a.** Connect them by using four M10 x 50mm Bolts, Nuts and Washers (3), and secure in place with the included Wrench (6).



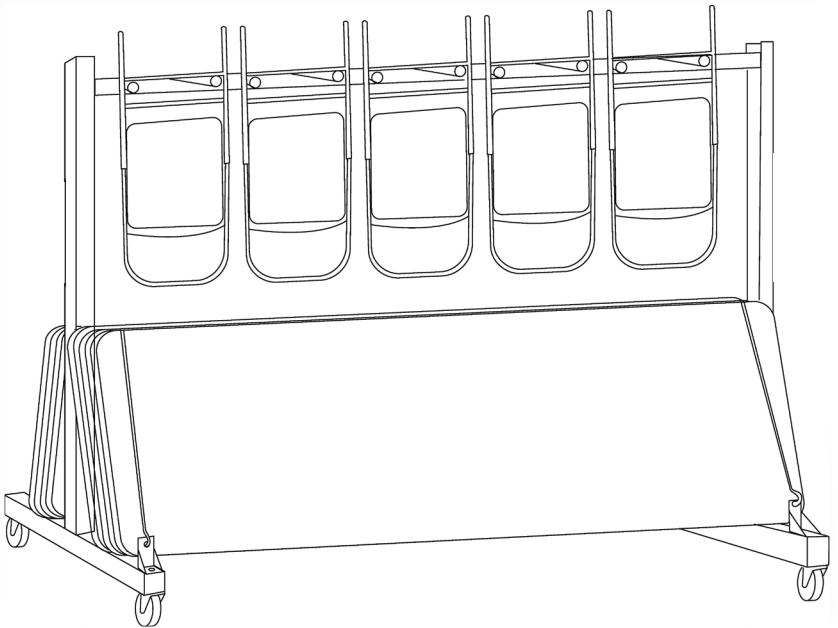
Step 3:

- A.** Align the holes in the Table Support (2) with the Base Rails (E), the Locking Caster Wheels (G), and Caster Wheels (H), as pictured.
- B.** Insert sixteen M8 x 16mm Bolts, Nuts, and Washers (4) and secure in place with the Wrench (6).



Using the Cart

- A.** Install tables onto the cart first.
 - a.** Be sure to stack them between the Upright (F) and the Table Supports (2).
- B.** Secure the tables onto the cart by hooking the Bungee Cords (1) into the Table Supports (2) and stretching over the tables.
- C.** Place the chairs upside down on the Chair Hangers (B).
 - a.** Be sure to use two hangers per chair.
- D.** Stack equal amounts of chairs and tables on each side.

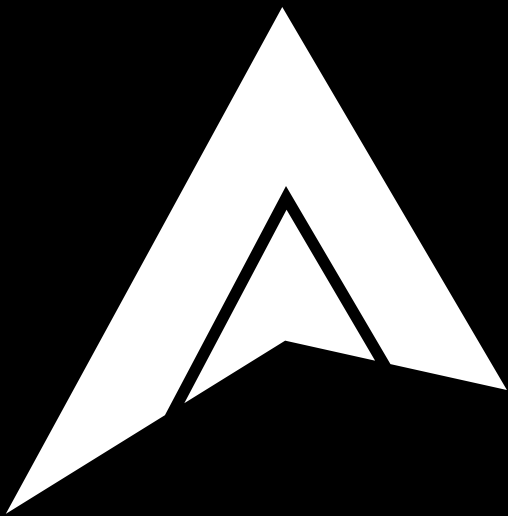


Care and Maintenance

- To clean the cart, dampen a cloth with water and wipe it down.
 - Do not use chemicals or cleaning agents.
 - Should you have caked-on dirt, use a mild soap and warm water mixture.
 - Towel dry the cart, ensuring you don't leave water or soap behind.
- Inspect bungees for cracks and replace them if necessary.
 - Do not use any bungee cords that show signs of damage as this can result in damage, or serious injury,
- Occasionally check castor wheels and oil if necessary.
 - If they show signs of damage, do not use them, and replace them immediately.

Limited Warranty

1. Adir Corp (the "Company" or "Tiger Companies") warrants to the purchaser that the product will be free from defects in workmanship and materials for a period of 1 year from the date of purchase. The warranty period is not extended if we repair, replace, exchange, or provide a refund for the product (as determined in our sole discretion). We may change the availability of this limited warranty at our discretion, but any changes will not be retroactive.
2. These warranties are not assignable or transferable to any other person, including, without limitation, any subsequent owner or other transferee of the product.
3. This Warranty does not apply to: (a) damage caused by misuse, tampering, abuse, neglect, or accident; (b) damage caused by improper installation, modification, or service; (c) alteration of the serial number; or (d) use that violates the instructions furnished by the Company will void this warranty.
4. The sole responsibility of the Company shall be limited to (a) the repair or replacement (in its sole discretion) of any component of the product which fails to conform to this; (b) a refund the purchase price of such product (in its sole discretion), at no cost to the purchaser for the period of the warranty, or (c) an exchange for a similar product, comparable in function and price.
5. Contact the Company directly at 1-(800)-805-1790 to obtain service under this warranty. If it becomes applicable to send a defective product to the Company, a Return Authorization Number must first be obtained from the Company. In order to obtain service under this warranty, purchaser may be required to provide the Company with the following items (a) proof of purchase, (b) photographs and or videos (of the damage, and (c) a written testimonial describing the defect.
6. Products shipped without prior Return Authorization and Return Authorization Number may not be accepted, and the Company will not be responsible for their disposition and/or cost of return to the owner.
7. The Company will not assume any responsibility for any loss or damage incurred in shipping and or delivery.
8. The product(s) must be returned within 14 calendar days of receiving the return authorization from the Company and must include the original proof of purchase for the warranty to be honored.
9. Any implied warranties that the purchaser may have are limited to the duration of the warranties described above. There are no further warranties that extend or apply beyond the face hereof, and the Company expressly disclaims and excludes any and all warranties of merchantability or fitness for a particular purpose. Some states do not allow limitations on how long an implied warranty lasts, so the above limitation may not apply to you.
10. THE REMEDIES DESCRIBED ABOVE ARE YOUR SOLE AND EXCLUSIVE REMEDIES AND THE COMPANY'S ENTIRE LIABILITY FOR ANY BREACH OF THIS LIMITED WARRANTY. OUR LIABILITY SHALL UNDER NO CIRCUMSTANCES EXCEED THE ACTUAL AMOUNT PAID BY YOU FOR THE DEFECTIVE PRODUCT, NOR SHALL WE UNDER ANY CIRCUMSTANCES BE LIABLE FOR ANY CONSEQUENTIAL, INCIDENTAL, SPECIAL OR PUNITIVE DAMAGES OR LOSSES, WHETHER DIRECT OR INDIRECT. SOME STATES DO NOT ALLOW THE EXCLUSION OR LIMITATIONS OF INCIDENTAL OR CONSEQUENTIAL DAMAGES, SO THE LIMITATION MAY NOT APPLY TO YOU.
11. This warranty gives you specific legal rights, and you may also have additional rights which vary from state to state.



ADI690-01

© 2023 Adir Office

adiroffice.com