

# BEFOUR

PROFESSIONAL HEALTHCARE SCALES

## Tilt & Roll Handrail Scale with BMI

**ADA COMPLIANT** **MODEL MX310**

Befour's MX310 bariatric scale is ideal for most patient weighing requirements. With a 1,000 pound capacity and specially designed handrails, the patient's weight is determined accurately and quickly, with maximum safety.

Moving the scale from room to room is effortless with its *"tilt & roll" design and large wheels*. Operation is simple and intuitive, even for the first time user.

The scale offers many *advanced features which come standard*, including Befour's proprietary MotionLock technology and ECO Weigh battery system for years of use and allows the scale to be used anywhere.

All Befour scales are **built to last**, constructed of anodized aluminum, backed by an 'industry leading' 3-year warranty and are **Made in the USA**.

### FEATURES & BENEFITS

**Integrated "Active" Handrail:** Allows patient to grasp handrail for support while weight is accurately calculated.

**Ergonomic Wrap-Around Handrail:** Unique, heavy-duty, design does not interfere with foot positioning and adds security and stability for patients of all sizes.

**Fully Assembled:** Arrives ready for use - simply insert the provided leveling feet and batteries.

**"Tilt & Roll" Design:** Safely weigh patient when scale is stationary, but ready to move at any time.

**Display Console:** LB/KG lockout, programmable settings, BMI output, auto zero, recall, reweigh ability, and more.



MotionLock automatically facilitates quick & accurate weight, even for the most unsteady user – no intervention of the care provider or patient required.



**EMR READY**



**HANDS-FREE WEIGHING**



**DISPLAY CONSOLE**

**Display is used across all Befour's medical scales:** Seamlessly move from one model to another with ease

**Displays weight, height, and BMI on a single screen**

**EMR connectivity** via serial output or other options

**Programmable User Settings** can be set to auto-off, "Hands-Free" Weighing, etc.

**'ECO Weigh' battery system** provides 100,000 weighings per set of (4) D-cell alkaline batteries (included)

**LB/KG Lockout:** Toggle between or set to display only your desired unit of measure

3-segment battery life indicator

Large 1" LCD digits

No AC outlet or recharging needed

# Tilt & Roll Handrail Scale with BMI

## MODEL MX310

### SCALE SPECIFICATIONS

SCALE HEIGHT	42"
PLATFORM DIMENSIONS	22" W x 25" D x 2" H
SYSTEM WEIGHT	46 lbs
WEIGHT CAPACITY	1000 lbs (450 kg)
RESOLUTION	0.1 lb (0.05 kg)
ACCURACY	± 0.1 lb (0.05 kg)
POWER SOURCE	4 D-cell alkaline batteries (incl)
BATTERY LIFE	100,000 weighings
CONNECTIVITY	USB serial or other options
DISPLAY READOUT	1" LCD digits
WARRANTY	3 years

### SHIPPING SPECIFICATIONS

PACKAGED WEIGHT	66 lbs
PACKAGE DIMENSIONS	Box (27" x 24" x 43")
SHIPPING METHOD	Freight

### DIMENSIONS

Allow 1" perimeter space - scale should not touch wall

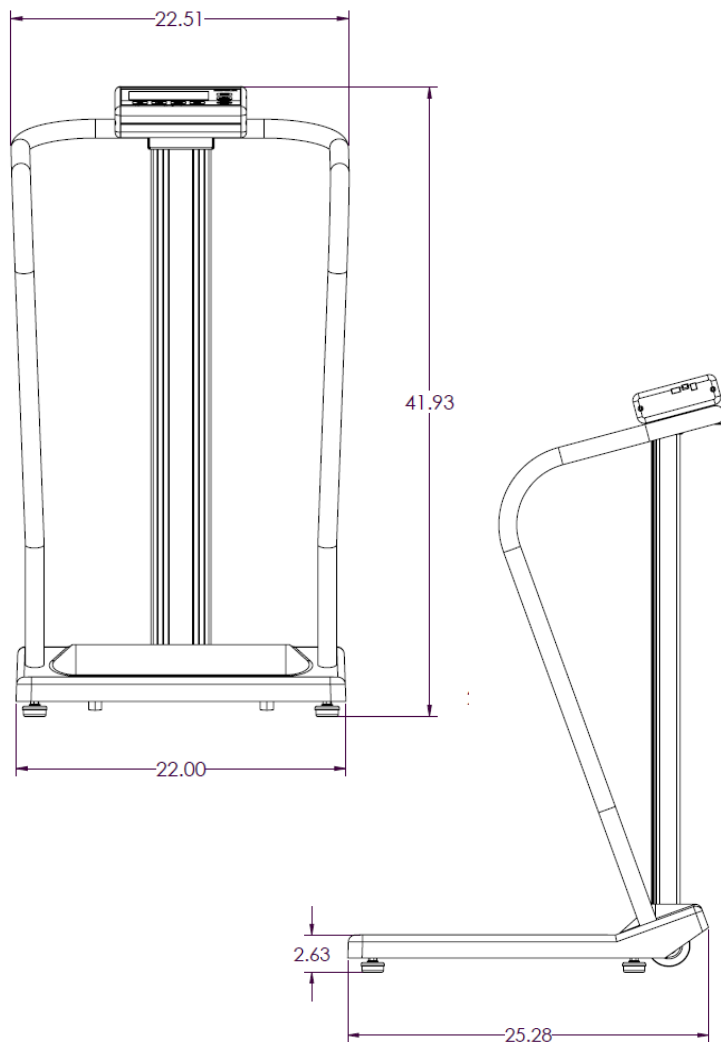

To move to a new location, simply tilt the scale back on its large 3" wheels and roll away.

The scale fits through all standard doorways.

**BEFOUR**

Befour Inc. | 102 Progress Drive, Saukville, WI 53080 | 800.367.7109 | f: 262.284.5966 | befour.com | sales@befour.com