



Magnifier

Epic[®] LED Magnifier

The perfect combination of light quality, positionability and large viewing area.

Burton's Epic LED Magnifier has an arm and neck system that is rugged and flexible. It stays exactly where it's positioned and doesn't require tightening or lock mechanism adjustments.

Features

- Large optical viewing area
- Superb light quality; 90 CRI, 4000 Kelvin
- 10-100% dimming capability
- Auto shut-off
- Smooth surface, easy to clean, anti-microbial coating
- Low maintenance LED array
- Medical standards approved
- Available in Floor Stand and Wall/Table Models
- 5-year limited warranty



burton[®]

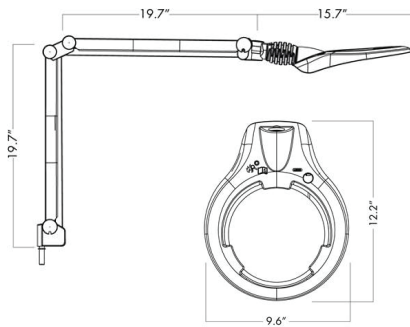

Magnification Table

Primary Lens Diopter	Secondary Lens Diopter (optional)	Total Magnification	Total Diopter	Magnification %	Focal Length (in.)
3.5		1.88X	3.5	188%	11
3.5	4.0	2.88X	7.5	288%	5
3.5	6.0	3.38X	9.5	338%	4
3.5	10.0	4.38X	13.5	438%	3

Summary of technical data

EPIC LED MAGNIFIER

Optics:	3.5 diopter (1.88X magnification)
Viewing area diameter:	6.5" (16.5 cm)
Illuminance:	1,360 lux (126 fc) at 8" (20 cm) 3,830 lux (356 fc) at 11" (28 cm)
Color Temperature:	4000 Kelvin
Color Rendering Index (CRI):	90
Light sources:	LED, 50,000-hours average rated bulb life
Power:	10 Watts
Mounting Options:	Mobile Floor Stand, Wall/Table Mount
Maximum Arm Reach:	39" (99 cm)
Applications:	General examination
Certifications/Approvals:	IEC 60601-1 (SAFETY), EC 60601-1-2, (EMC)
Product warranty:	5-year limited

Ordering Information

EPIC LED MAGNIFIER

Universal Input 100-240v 50/60Hz Model		Description
EMLFL		Epic LED Magnifier, Floor, NEMA 5-15P
EMLT		Epic LED Magnifier, Table, NEMA 5-15P
EMLW		Epic LED Magnifier, Wall, NEMA 5-15P
EMLFL01		Epic LED Magnifier, Floor, CEE 7/7
EMLFL02		Epic LED Magnifier, Floor, AS/NZS 3112
EMLFL03		Epic LED Magnifier, Floor, BSI363
EMLT01		Epic LED Magnifier, Table, CEE 7/7
EMLT02		Epic LED Magnifier, Table, AS/NZS 3112
EMLT03		Epic LED Magnifier, Table, BSI363
EMLW01		Epic LED Magnifier, Wall, CEE 7/7
EMLW02		Epic LED Magnifier, Wall, AS/NZS 3112
EMLW03		Epic LED Magnifier, Wall, BSI363

ACCESSORIES

Model	Description
EML4DS	4 Diopter Lens Attachment
EML6DS	6 Diopter Lens Attachment
EML10DS	10 Diopter Lens Attachment

IEC Plug Type



Default (No Code): NEMA 5-15P 01: CEE 7/7 02: AS/NZS 3112 03: BSI363

Add appropriate Plug Type to the end of the model number.¹

EMLFL 01
 Model Plug Type¹

Example 1: EMLFL for a 100-240v Floor Stand Model with Nema 5-15P Plug.

Example 2: EMLFL01 for a 100-240v Floor Stand Model with SCHUKO CEE 7/7 to C60320C13Plug.

¹ 100-120v Do not add Plug Type, NO CODE: NEMA 5-15P, 01: CEE 7/7, 02:AS/NZS 3112, 03:BSI363.



© 2018 Burton Medical. All rights reserved.
 Burton Medical reserves the right to make changes in specifications and/or to discontinue any product at any time without notice or obligation and will not be liable for any consequences resulting from the use of this publication.

burton®

Burton Medical, LLC
 2300 W Windsor Ct., Suite C
 Addison, IL 60101 USA
 Phone (800) 444-9909, Fax (800) 765-1770
 Burtonmedical.com