



461

& 403 user manual



SETUP
VIDEO



OPERATION
VIDEO



USER
MANUAL

THIS PAGE IS INTENTIONALLY BLANK

Table of Contents

| | |
|---|----|
| APPLICABLE MODEL(S)..... | IV |
| REVISION HISTORY TABLE | IV |
| GENERAL INFORMATION | 1 |
| Purpose of this Manual..... | 1 |
| Intended Use..... | 1 |
| Training Options..... | 1 |
| Symbols and Warnings..... | 2 |
| Safety Instructions | 4 |
| Electromagnetic Interference | 5 |
| Electromagnetic Compatibility (EMC)..... | 5 |
| Electrical Requirements | 8 |
| Contraindications..... | 9 |
| Transportation and Storage Conditions | 9 |
| Disposal of Equipment | 9 |
| EQUIPMENT FEATURES | 10 |
| INSTALLATION | 11 |
| Required Tools | 11 |
| Explanation of Instructions | 11 |
| Unpacking and Set-up..... | 12 |
| OPERATION | 14 |
| Operating Conditions | 14 |
| Soft Start and Stop Technology | 14 |
| Program Positions | 14 |
| Any Button Cancellation Technology | 14 |
| Current Sensing Technology..... | 14 |
| Shutdown..... | 14 |
| Controls..... | 15 |
| Headrest Operation | 16 |
| Armrest Operation..... | 17 |
| Footrest Operation (461 Model Only)..... | 17 |
| Swivel Operation..... | 17 |
| LIST OF ACCESSORIES..... | 18 |
| MAINTENANCE | 19 |
| Disinfection | 19 |
| Cleaning | 20 |
| Preventative Maintenance..... | 20 |
| Calls for Service..... | 20 |
| LIMITED WARRANTY | 21 |
| TROUBLESHOOTING GUIDE..... | 22 |
| SOUND GUIDE..... | 23 |
| SPECIFICATIONS..... | 24 |
| IN-SERVICE CHECKLIST | 25 |

APPLICABLE MODEL(S)

This manual is for the following product numbers and serial numbers:

| PRODUCT NUMBER | DESCRIPTION | EFFECTIVE S/N |
|----------------|--------------------------------------|--------------------------|
| 461-002-XX | 461 Exam Chair, Swivel Top, 100-240V | 250101-XXXXXX to Current |
| 403-002-XX | 403 Exam Chair, Swivel Top, 100-240V | 250101-XXXXXX to Current |

REVISION HISTORY TABLE

| DATE | REVISION | CO#/ECO# | DETAILS |
|------------|----------|----------|---|
| 03/01/2023 | A | CO-0393 | Initial release |
| 12/4/2024 | B | CO-0501 | Updated Manual to reflect change to upholstered arm cushion. |
| 12/16/2025 | C | CO-0594 | Updated images with new headrest knob. Updated List of Accessories. |

User Manual

MTI 461 & 403

GENERAL INFORMATION

Purpose of this Manual

This manual covers the safety, installation, instructions for use, and maintenance of this equipment. It is intended that it be used by the service professional installing the equipment and by the medical professionals who have been trained to use it. No repair information is included with this manual because no operator repairs are intended.

Intended Use

This equipment is intended to be used as a chair/table for general examinations and procedures performed by a qualified medical professional in a medical office environment.

Training Options

Training is based on the intended use of the equipment and the proficiency of the medical professionals who will be using the equipment. Training is accomplished either through reading the installation and operation sections of the user manual or through remote training provided by MTI Technical Support. To request training, contact MTI.

PRODUCT INFORMATION

Date of Purchase: _____

Model Number: _____

Serial Number: _____

(see "EQUIPMENT FEATURES" on page 10 for location of serial number label)

Symbols and Warnings

This manual contains Notices, Cautions, and Warnings, which are meant to call attention to particular parts or sections of this manual. Since safety is of our utmost concern, this manual should be read by all personnel who will be operating this medical equipment.

Symboles et Avertissements

Ce manuel contient des avis, des précautions et des avertissements qui sont destinés à attirer l'attention sur des pièces ou des sections de ce manuel particulier. Parce que la sécurité est notre première préoccupation, ce manuel doit être lu par tout le personnel qui sera d'utiliser cet équipement médical.

WARNINGS/AVERTISSEMENTS

Are used to call attention to condition, practice, or procedure, which could cause personal injury if not followed correctly. Please become familiar with all warnings and observe them at all times.

Sont utilisés pour attirer l'attention sur une condition, pratique ou procédure qui pourrait causer des blessures s'il n'est pas suivi correctement. S'il vous plaît se familiariser avec tous les avertissements et les observer à tout moment.

CAUTIONS/PRÉCAUTIONS















Are used to call attention to a condition, practice, or procedure which could cause product damage if not used correctly.









Sont utilisés pour attirer l'attention sur une condition, pratique ou procédure qui pourrait causer des dommages au produit s'il n'est pas utilisé correctement.

NOTICES/AVIS

Are used to call attention to helpful information regarding a condition, practice, or procedure.

Sont utilisés pour attirer l'attention sur des informations utiles concernant une condition, pratique ou de procédure.

| | |
|---|---|
|  | Type B applied part Type B, partie appliquée |
|  | Proper shipping orientation for the product Orientation d'embarquement correct pour le produit |
|  | Product is fragile; be careful in handling Le produit est fragile. Soyez prudent lors de la manipulation |
|  | Protective earth ground Terre électrique de protection |
|  | Alternating current Le courant alternatif |
|  | Product must be kept dry Le produit doit rester sèche |
|  | Upper and lower limits of temperature Limites haute et basse de la température |
|  | Maximum stacking height of palletized units. Hauteur maximale de la pile d'unités sur palettes. |
|  | Indicates the presence of a dangerous voltage/shock hazard Indique la présence de voltage dangereux/ de choc |
|  | Follow instructions for use Suivez les instructions pour l'utilisation |
|  | Consult operating instructions Consultez les instructions d'utilisation |
|  | Manufacturer of product Fabricant de produits |
|  | Date on which the product was manufactured Date de fabrication |
|  | Identifies the manufacturer's serial number Identifie le numéro de série du fabricant |

| | |
|---|---|
|  | Upper and lower limits of relative humidity <i>Limites haute et basse de humidité relative</i> |
|  | Upper and lower limits of atmospheric pressure <i>Limites haute et basse de la pression atmosphérique</i> |
| N | Connection point for the neutral conductor <i>Point de connexion pour le conducteur neutre</i> |
| L | Connection point for the live conductor <i>Point de connexion pour le conducteur sous tension</i> |
| G | Connection point for the protective earth (ground) conductor <i>Point de connexion pour le conducteur de protection (fil de masse)</i> |
|  | (WEEE) Waste of Electrical and Electronic Equipment <i>Déchets d'équipements électriques et électroniques</i> |
|  | ETL listing mark <i>Marque ETL Listé</i> |
|  | UL listing mark <i>Marque UL Listé</i> |
| CE | European Conformity mark <i>Marque Conformité Européenne</i> |
| RoHS | RoHS Compliant <i>Conforme à RoHS</i> |
|  | Hospital Grade (green dot) <i>De qualité hôpital (point vert)</i> |
|  | TUV listing mark <i>Marque TUV Listé</i> |
|  | Emergency Stop <i>Arrêt d'urgence</i> |

Safety Instructions

WARNING/AVERTISSEMENT

Read this manual before installation and use.

Lisez ce manuel avant l'installation et l'utilisation.

WARNING/AVERTISSEMENT

No modification of this equipment is allowed.

Aucune modification de cet équipement est autorisée.

WARNING/AVERTISSEMENT

Do not operate equipment in the presence of flammable anesthetics.

Ne pas faire fonctionner l'équipement en présence d'anesthésiques inflammables.

WARNING/AVERTISSEMENT

Do not leave the equipment unattended during use of programmable buttons (Home/P1-P2) or manual actuation of a function.

Ne laissez pas l'appareil sans surveillance pendant l'utilisation des positions programmées (position retournée/P1-P2) ou l'actionnement manuel d'une fonction.

WARNING/AVERTISSEMENT

Ensure equipment, patient, and other objects are in a safe condition before operating the equipment.

Assurer l'appareil, patient, et d'autres objets sont dans un état sûr avant d'utiliser l'appareil.

WARNING/AVERTISSEMENT

Verify patient arms, headrest and other adjustable equipment features and accessories are locked and in a safe and secure position before use.

Vérifiez que les accoudoirs, l'appui-tête et les autres éléments et accessoires de l'équipement ajustable sont verrouillés et dans une position sûre avant toute utilisation.

WARNING/AVERTISSEMENT

Ensure controls, cords, and other parts of the equipment do not create a tripping or other safety hazard for operator or patient.

Vérifiez les contrôles, les cordons et les autres parties de l'équipement ne créent pas un risque de trébuchement ou d'autres risques d'accident pour l'opérateur ou le patient.

WARNING/AVERTISSEMENT

Exceeding the specified load limit of any equipment component may result in personal injury or property damage. See "Specifications" on page 24.

Le dépassement de la limite de poids spécifiée de tout composant de l'équipement peut entraîner des blessures ou des dommages matériels. Voir «Specifications» à la page 24.

WARNING/AVERTISSEMENT

Backrest, seat, footrest, armrest, headrest, and other parts of the equipment should only be used for their intended purpose. MTI is not responsible for use of components outside of their intended use.

Le repose-dos, reste de siège, repose pieds, accoudoirs, appui-tête et d'autres parties de l'équipement ne doivent être utilisés conformément à leur utilisation prévue. MTI n'est pas responsable de l'utilisation des composants au dehors de leur utilisation prévue.

WARNING/AVERTISSEMENT

This product can expose you to chemicals including nickel, which is known to the State of California to cause cancer. For more information go to www.P65Warnings.ca.gov and see www.mti.net/faqs for details on California Proposition 65.

Ce produit peut vous exposer à des agents chimiques, y compris le nickel, identifiés par l'État de Californie comme pouvant causer le cancer. Pour de plus d'informations, prière de consulter www.P65Warnings.ca.gov et voir www.mti.net/faqs pour les détails sur la Proposition de Californie 65.

WARNING/AVERTISSEMENT

The magnet in the footrest (461 Model only) may temporarily affect the function or programming of some implantable pacemakers or defibrillators. Avoid positioning the torso of patients who have these types of implanted devices near the center of the footrest.

L'aimant dans le repose-pieds (Modèle 461 uniquement) peut affecter temporairement le fonctionnement ou la programmation de certains stimulateurs cardiaques implantables ou défibrillateurs. Évitez de positionner le torse des patients qui ont de ces types de dispositifs implantés près du centre du repose-pieds.

Electromagnetic Interference

This equipment is designed and built to minimize electromagnetic interference with other devices. However, if interference is noticed between another device and this equipment, do one or more of the following:

1. Ensure other device is operating within its specifications.
2. Plug equipment into isolated circuit.
3. Remove interfering device from room.
4. Increase separation between equipment and interfering device.
5. Contact MTI if electromagnetic interference persists.

Electromagnetic Compatibility (EMC)

WARNING/AVERTISSEMENT

Use of accessories, transducers and cables other than those specified or provided by the manufacturer of this equipment could result in increased electromagnetic emissions or decreased electromagnetic immunity of this equipment and result in improper operation.

L'utilisation d'accessoires, de transducteurs et de câbles autres que ceux spécifiés ou fournis par le fabricant de cet équipement peut induire une augmentation des émissions électromagnétiques ou une diminution de l'immunité électromagnétique de cet équipement et entraîner un mauvais fonctionnement.

WARNING/AVERTISSEMENT

During use, portable RF communications equipment (including peripherals such as antenna cables and external antennas) should be used no closer than 30 cm (12 inches) to any part of the chair, including cables specified by the manufacturer. Otherwise, degradation of the performance of this equipment could result.

Les équipements de communication RF portables (y compris les périphériques tels que les câbles d'antenne et les antennes externes) ne doivent pas être utilisés à moins de 30 cm (12 po) de toute partie de la chaise, y compris les câbles spécifiés par le fabricant, pour éviter tout risque de dégradation des performances de cet équipement.

WARNING/AVERTISSEMENT

Use of this equipment adjacent to other electrical equipment should be avoided since it could result in improper operation. If such use is necessary, verify normal chair operation before use with patients.

L'utilisation de cet équipement à proximité d'autres équipements électriques doit être évitée car cela pourrait entraîner un mauvais fonctionnement. Si une telle utilisation est nécessaire, vérifier le fonctionnement normal du fauteuil avant de l'utiliser avec les patients.

NOTICE/AVIS

The emissions characteristics of this equipment make it suitable for use in industrial areas and hospitals (CISPR 11 class A). If it is used in a residential environment (for which CISPR 11 class B is normally required) this equipment might not offer adequate protection to radio-frequency communication services. The user might need to take mitigation measures, such as relocating or re-orienting the equipment.

Les caractéristiques d'émission de cet équipement le rendent approprié pour une utilisation dans les zones industrielles et les hôpitaux (CISPR 11 classe A). S'il est utilisé dans un environnement résidentiel (pour lequel la norme CISPR 11 de classe B est normalement requise), cet équipement peut ne pas offrir une protection adéquate aux services de communication radio fréquence. L'utilisateur peut avoir besoin de prendre des mesures d'atténuation, telles que le déplacement ou la réorientation de l'équipement.

This chair has been tested to comply with the requirements of EN 60601-1-2:2014 Ed.4 for electromagnetic compatibility (EMC). The chair was designed to be operated within the electromagnetic environment specified below.

| Guidance and manufacturer's declaration - electromagnetic emissions | | |
|---|------------|---|
| Emissions Test | Compliance | Electromagnetic Environment - Guidance |
| RF emissions CISPR 11 | Group 1 | The 461 & 403 Procedure Chairs use RF energy only for its internal function. Therefore, its RF emissions are very low and are not likely to cause any interference in nearby electronic equipment. |
| RF emissions CISPR 11 | Class A | The 461 & 403 MTI Procedure Chairs are suitable for use in all establishments other than domestic and those directly connected to public low-voltage power supply network that supplies buildings used for domestic purposes. |
| Harmonic Emissions IEC 6100-3-2 | Class A | |
| Voltage fluctuations/flicker emissions IEC 61000-3-3 | Complies | |

| RECOMMENDED SEPARATION DISTANCES BETWEEN PORTABLE AND MOBILE RF COMMUNICATIONS EQUIPMENT AND THE MTI PROCEDURE CHAIRS | | | |
|--|--|---|--|
| The MTI Exam/Procedure Chair is intended for use in an electromagnetic environment in which radiated RF disturbances are controlled. The customer or the user of the MTI Procedure Chair can help prevent electromagnetic interference by maintaining a minimum distance between portable and mobile RF communications equipment (transmitters) and the MTI Procedure Chair as recommended below, according to the maximum output power of the communications equipment. | | | |
| Rated maximum output power of transmitter Watts (W) | Separation distances according to frequency of transmitter meters (m) | | |
| | 150 kHz to 80 MHz $d = (1.17)(\sqrt{P})$ | 80 MHz to 800 MHz $d = (1.17)(\sqrt{P})$ | 800 MHz to 2.5 GHz $d = (2.33)(\sqrt{P})$ |
| 0.01 | 0.12 | 0.12 | 0.23 |
| .1 | 0.37 | 0.37 | 0.74 |
| 1 | 1.17 | 1.17 | 2.33 |
| 10 | 3.69 | 3.69 | 7.38 |
| 100 | 11.70 | 11.70 | 23.30 |
| For transmitters rated at a maximum output power not listed above, the recommended separation distance d in meters (m) can be estimated using the equation applicable to the frequency of the transmitter, where P is the maximum output power rating of the transmitter in watts (W) according to the transmitter manufacturer. | | | |
| NOTE 1: At 80 MHz and 800 MHz, the separation distance for the higher frequency range applies. | | | |
| NOTE 2: These guidelines may not apply in all situations. Electromagnetic propagation is affected by absorption and reflection from structures, objects and people. | | | |

GUIDANCE AND MANUFACTURER'S DECLARATION - ELECTROMAGNETIC IMMUNITY

The MTI Exam/Procedure Chair is intended for use in the electromagnetic environment specified below. The customer or the user of the MTI Exam/Procedure Chair should assure that it is used in such an environment.

| Immunity Test | IEC 60601 Test Level | Compliance Level | Electromagnetic Environment Guidance |
|-------------------------------|----------------------------|------------------|--|
| Conducted RF IEC 61000-4-6 | 3V rms 150kHz to 80 MHz | 3V | Portable and mobile RF communications equipment should be used no closer to any part of the MTI Procedure Chair, including cables, than the recommended separation distance calculated from the equation applicable to the frequency of the transmitter. Recommended separation distance: $d = (1.17)(\sqrt{P})$ 150 kHz to 80 MHz $d = (1.17)(\sqrt{P})$ 80 MHz to 800 MHz $d = (2.33)(\sqrt{P})$ 800 MHz to 2.5 GHz Where P is the maximum output power rating of the transmitter in watts (W) according to the transmitter manufacturer and d is the recommended separation in meters (m). Field strengths from fixed RF transmitters, as determined by an electromagnetic site survey ^a should be less than the compliance level in each frequency range. ^b Interference may occur in the vicinity of equipment marked with the following symbol:  |
| Radiated RF IEC 61000-4-3 | 3V/m 80MHz to 2.7 Ghz | 3V/m | |

NOTE 1: At 80 MHz and 800 MHz, the higher frequency range applies.

NOTE 2: These guidelines may not apply in all situations. Electromagnetic propagation is affected by absorption and reflection from structures, objects and people.

^aNOTICE: Field strengths from fixed transmitters, such as base stations for radio (cellular/cordless) telephones and land mobile radios, amateur radio, AM and FM radio broadcast and TV broadcast cannot be predicted theoretically with accuracy. To assess the electromagnetic environment due to fixed RF transmitters, an electromagnetic site survey should be considered. If the measured field strength in the location in which the MTI Procedure Chair is used exceeds the applicable RF compliance level above, the MTI Procedure Chair should be observed to verify normal operation. If abnormal performance is observed, additional measures may be necessary, such as re-orienting or relocating the MTI Procedure Chair.

^aAVIS: Les forces de champ des émetteurs fixes, telles que les stations de base pour les téléphones radio (cellulaires / sans fil) et les radios mobiles terrestres, la radio amateur, les émissions de radio AM et FM et les émissions de télévision ne peuvent pas être prédites avec précision. Pour évaluer l'environnement électromagnétique dû aux émetteurs RF fixes, une étude de site électromagnétique doit être envisagée. Si le mesuré la résistance au champ dans le lieu où le fauteuil de procédure MTI est utilisé dépasse le niveau de conformité RF applicable indiqué ci-dessus, le MTI Le président de procédure doit être observé pour vérifier le bon fonctionnement. Si des performances anormales sont observées, des mesures supplémentaires peuvent être nécessaires, telles que la réorientation ou le déplacement du fauteuil de procédure MTI.

^bOver the frequency range 150kHz to 80MHz, field strengths should be less than 3 V/m.

| GUIDANCE AND MANUFACTURER'S DECLARATION - ELECTROMAGNETIC IMMUNITY | | | |
|---|---|---|---|
| The MTI Exam/Procedure Chair is intended for use in the electromagnetic environment specified below. The customer or the user of the MTI Exam/Procedure Chair should assure that it is used in such an environment. | | | |
| Immunity Test | IEC 60601 Test Level | Compliance Level | Electromagnetic Environment Guidance |
| Electrostatic discharge (ESD) IEC 61000-4-2 | ± 8 kV contact ± 8 kV air | ± 8 kV contact ± 2, 4, 8, 15 kV air | Floors should be wood, concrete or ceramic tile. If floors are covered with synthetic material, the relative humidity should be at least 30%. |
| Electrical fast Transient / burst IEC 61000-4-4 | ± 0.5, 1, 2 kV for power supply lines ± 1 kV for input/output lines | ± 0.5, 1, 2 kV for power supply lines ± 1 kV for input/output lines | Mains power quality should be that of a typical commercial or hospital environment. |
| Surge IEC 61000-4-5 | ± 0.5, 1 kV line(s) to line(s) ± 0.5, 1, 2 kV lines(s) to earth | ± 0.5, 1 kV ± 0.5, 1, 2 kV | Mains power quality should be that of a typical commercial or hospital environment. |
| Voltage dips, short interruptions and voltage variations on power supply input lines IEC 61000-4-11 Tested at 230, 220, 127 and 120 VAC. | 0% U_T (100% dip in U_T) for 0.5 cycle 0% U_T (100% dip in U_T) for 1 cycle 70% U_T (30% dip in U_T) for 25 cycles 0% U_T (100% dip in U_T) for 250 cycles | 0% U_T (100% dip in U_T) for 0.5 cycle 0% U_T (100% dip in U_T) for 1 cycle 70% U_T (30% dip in U_T) for 25 cycles 0% U_T (100% dip in U_T) for 250 cycles | Mains power quality should be that of a typical commercial or hospital environment. If the user of the MTI Procedure Chair requires continued operation during power mains interruptions, it is recommended that the MTI Exam/Procedure Chair be powered from an uninterruptible power supply or a battery. |
| Power frequency (50/60 Hz) magnetic field IEC 61000-4-8 | 30 A/m | 30 A/m, 50 / 60 Hz | Power frequency magnetic fields should be at levels characteristic of a typical location in a typical commercial or hospital environment. |
| NOTE: U_T is the a.c. mains voltage prior to application of the test level. | | | |

Electrical Requirements

WARNING/AVERTISSEMENT

To avoid risk of electrical shock, this equipment must be connected to a supply mains with protective earth.

Pour éviter tout risque de choc électrique, cet appareil doit être branché sur une prise électrique avec la terre électrique de protection.

WARNING/AVERTISSEMENT

Grounding reliability can only be achieved when the equipment is connected to an equivalent receptacle marked "Hospital Only" or "Hospital Grade".

Mise à la terre fiabilité ne peut être atteint lorsque l'appareil est connecté à un réceptacle équivalent marqué "Hôpital Uniquement" ou "de Qualité Hôpital".

⚠ WARNING/AVERTISSEMENT

When using endocardial catheters or high frequency surgical/ procedure devices, use non-conductive material to insulate the patient from metal portions of the equipment. Failure to comply may result in electric shock or burns to patient.

Lors de l'utilisation de cathéters endocavitaires ou dispositifs chirurgicale / procédure haute fréquence, utiliser un matériau non conducteur pour isoler le patient des parties métalliques de l'équipement. Le non-respect peut entraîner un choc électrique ou de brûlures pour le patient.

⚠ WARNING/AVERTISSEMENT

Connecting electrical equipment to multiple socket-outlet effectively leads to creating a medical electronic system and can result in a reduced level of safety.

Connexion d'un équipement électrique à une prise de courant multiple crée un système électronique médicale, et peut entraîner une baisse du niveau de sécurité.

⚠ WARNING/AVERTISSEMENT

Equipment must be positioned in normal use such that the power cords can be easily accessed to unplug.

L'appareils doit être positionné en utilisation normale telle que les cordons d'alimentation peuvent être facilement accessibles à débrancher.

⚠ WARNING/AVERTISSEMENT

Equipment must be connected to an appropriate power source when loss of power source would result in an unacceptable risk.

L'appareils doivent être relié à une source d'alimentation appropriée en cas de perte de la source d'alimentation entraînerait un risque inacceptable.

⚠ WARNING/AVERTISSEMENT

Do not use a three to two prong adapter to plug the equipment into a two conductor outlet, as grounding reliability is not maintained.

Ne pas utiliser un adaptateur non de prise de terre pour brancher l'appareil sur une prise à deux conducteurs, la fiabilité de la terre n'est pas maintenue.

⚠ WARNING/AVERTISSEMENT

Do not plug this equipment into a low power or auxiliary outlet. This equipment must be connected to a 100-240 Volt AC (VAC), 47-63 Hertz (Hz) outlet. If this equipment is connected to an insufficient power source, it will cause irreparable damage to this device's electronics.

Ne branchez pas cet équipement sur une prise de faible puissance ou une prise auxiliaire. Cet équipement doit être branché sur une prise de 100-240 Volt AC (VAC), 47-63 Hertz (Hz). Si cet équipement est connecté à une source d'alimentation insuffisante, il causera des dommages irréparables à l'électronique de cet appareil.

⚠ NOTICE/AVIS



The power cord may be used to simultaneously isolate both poles of the power supply by removing the power cord at the wall receptacle.

Le cordon d'alimentation peut être utilisé pour isoler simultanément les deux pôles de l'alimentation en retirant le cordon d'alimentation à la prise murale.

Contraindications

None.

Transportation and Storage Conditions

| | | |
|---|----------------------|---|
|  | Ambient Temperature | -10°C to +50°C (+14°F to +122°F) |
|  | Relative Humidity | 20-90% (non-condensing) |
|  | Atmospheric Pressure | 700 hPa to 1060 hPa (0.69 atm to 1.05 atm) |

Disposal of Equipment

At the end of product life, the equipment, accessories, and other consumable goods may have become contaminated due to normal medical use. Consult local codes and ordinances for proper disposal of equipment, accessories and other consumable goods.

EQUIPMENT FEATURES

Description of 461/403 Chair

The 461 Exam Chairs have power lift and back functions with coordinated leg rest and footrest functions. The 461 Exam Chairs have a 550 lb. (249 kg) patient capacity. The 461 Exam Chairs are 21" (53.3 cm) wide with an entry height of 21" (53.3 cm). All 461 Exam Chairs are manual Swivel Top models. The 461 Exam Chairs will rise to a height of 38" (96.5 cm).

The 403 Exam Chairs have power lift and back functions with a fixed footrest loop. The 403 Exam Chairs have a 550 lb. (249 kg) patient capacity. The 403 Exam Chairs are 21" (53.3 cm) wide with an entry height of 21" (53.3 cm). All 403 Exam Chairs are manual Swivel Top models. The 403 Exam Chairs will rise to a height of 38" (96.5 cm).

461 EXAM CHAIR

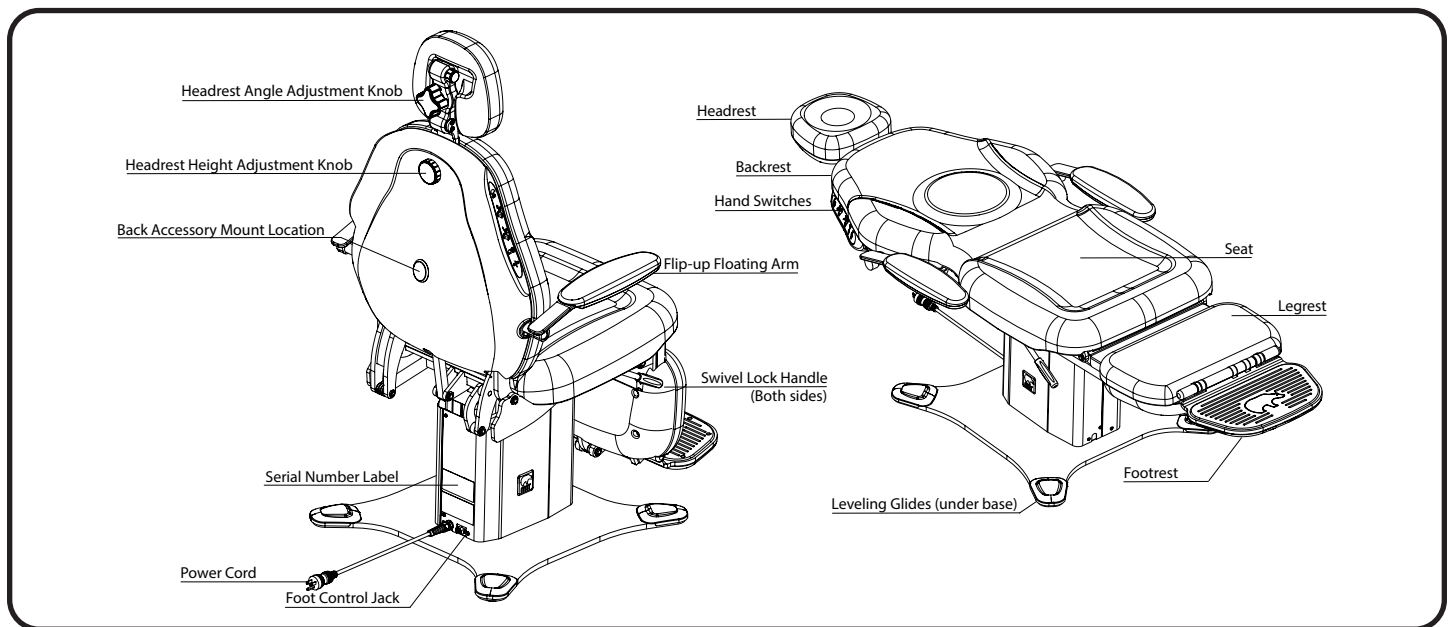

403 EXAM CHAIR

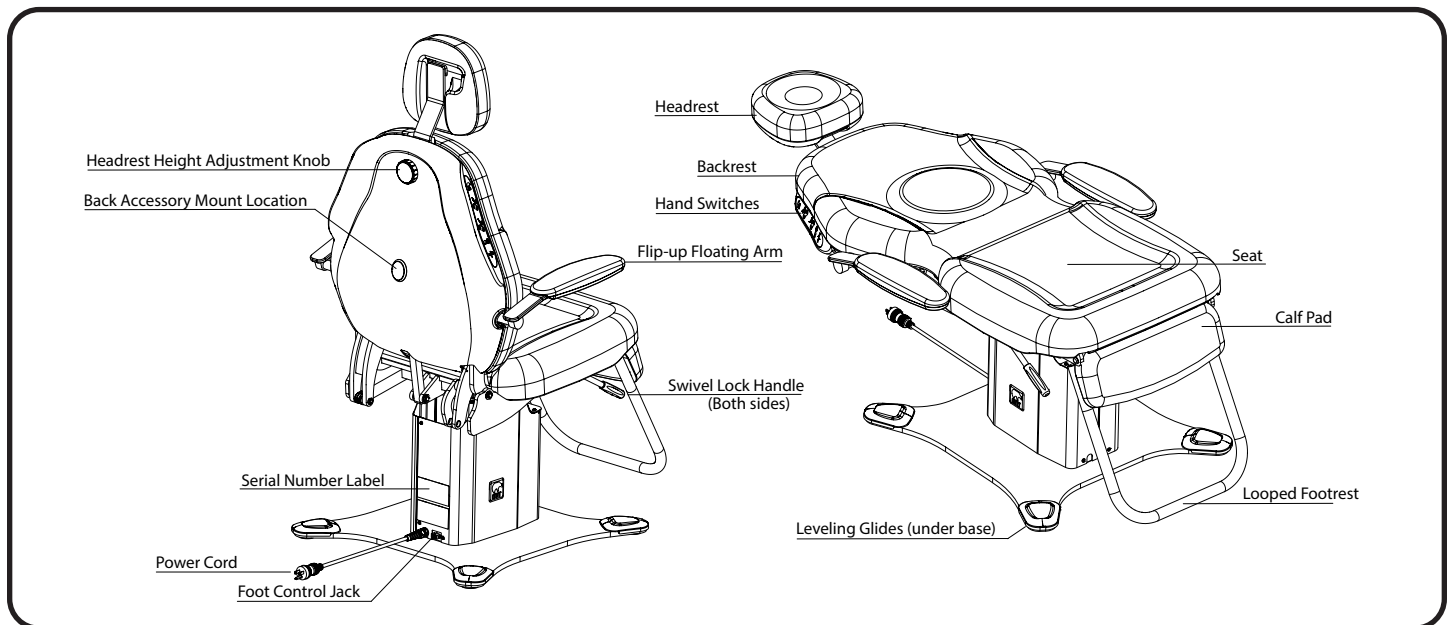

INSTALLATION

WARNING/AVERTISSEMENT

This equipment is heavy. Get help to remove it from the shipping pallet. Use proper lifting procedures when lifting to avoid serious back injury.

Cet équipement est lourd. Obtenir de l'aide pour le retirer de la palette d'expédition. Utilisez les procédures propre de levage pour le soulever pour éviter grave blessure au dos.

WARNING/AVERTISSEMENT

After equipment is installed, verify programmable positions (P1-P2) are safe and known positions.

Après l'équipement est installé, vérifier les positions programmables (P1-P2) sont des positions sûres et connues.

CAUTION/PRÉCAUTION

To move equipment, lift only from the equipment's main structure.

Pour déplacer l'appareil, soulevez seulement de la structure principale de l'appareil.

NOTICE/AVIS

If this product has been exposed to low temperatures, allow adequate time for it to warm to room temperature before putting it into service.







Si ce produit a été exposé à de basses températures, laisser suffisamment de temps pour lui permettre de se réchauffer à température ambiante avant de le mettre en service.

NOTICE/AVIS

Inspect the shipping boxes for visible damage. Record on bill of lading, photograph, report any damage to the carrier immediately, and contact MTI Technical Support. Request an inspection by the carrier if any concealed damage is noted.

Inspectez les boîtes d'expédition pour les dommages visibles. Fiche sur le connaissance, prendre une photo, et signalez immédiatement tout dommage au transporteur et contactez le support technique de MTI. Demander une inspection par le transporteur en cas de dommage caché est noté.

Required Tools

| | | | | | | | |
|---|---|---|----------------------|---|------------------------|---|--------------|
|  | Adjustable Wrench |  | Utility Knife |  | Flat Head Screw Driver |  | 7/16" Wrench |
|  | Set of Standard US Allen Wrenches (for Accessories) |  | Phillips Screwdriver | | | | |

Explanation of Instructions

Instructions have steps which are designated by a number. Each step may also have sub-steps designated by a letter. For example, an instruction to fasten an accessory may have 4 steps (1-4) and each of those steps may have sub-steps (A-B) to be performed before moving onto the next step.

Unpacking and Set-up

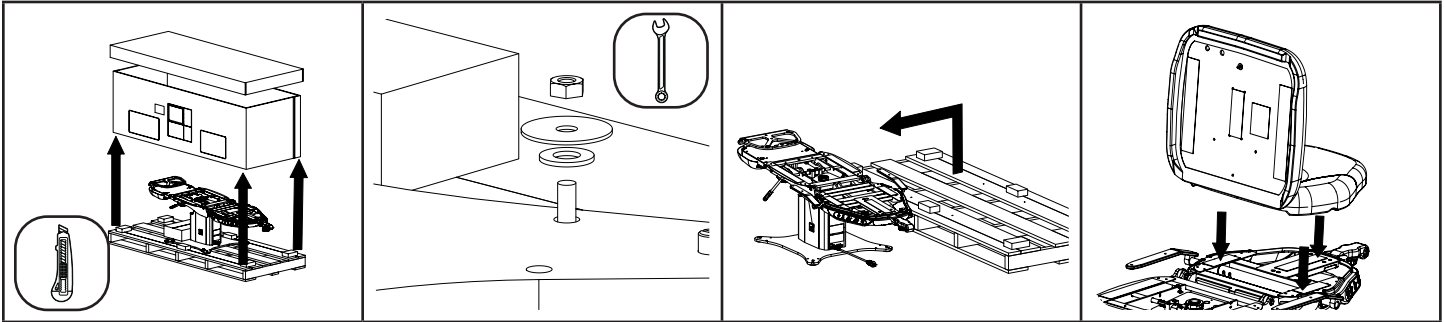

1. Remove shipping straps, shipping box, and other boxes from the pallet.

2. Remove (4) shipping bolts with an adjustable or 7/16" end wrench.

3. Slide the chair off the pallet. To move equipment, lift only from the equipment's main structure. Recycle packaging.

4. With the back and seat sections of the chair in the flat position, center the back portion of the seat/back cushion on the back section of the chair while holding up the seat portion of the cushion.

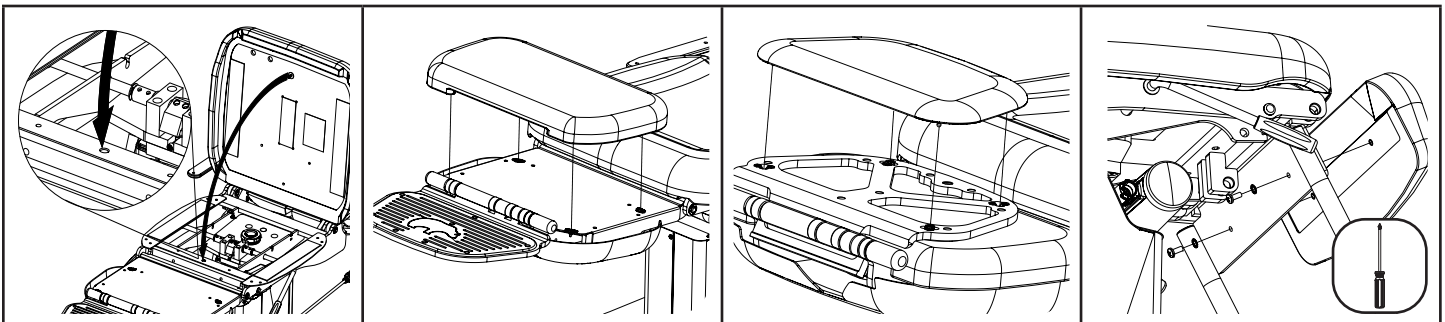

5. Lower the seat portion of the seat/back cushion into place and ensure that the ball stud enters the mating hole in the seat section of the chair.

6. **461 Model Only:** Attach the foot cushion by aligning the ball studs to the receptacles and pressing evenly to snap all 4 ball studs in place at the same time.

7. **461 Model Only:** Flip the footrest over. Attach the footrest cushion to the bottom of the footrest by aligning the ball studs to the receptacles and pressing evenly to snap all 4 ball studs in place.

8. **403 Model Only:** Using a Phillips® screwdriver, attach the calf pad cushion to the foot loop using the provided (2) screws and (2) star washers .

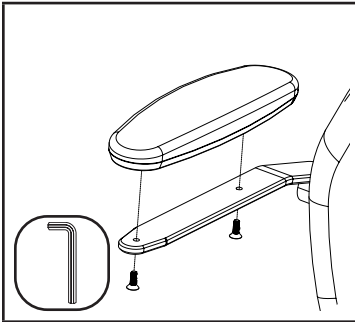

9. Using a 5/32" Allen® wrench, attach the arm cushion to each arm using the provided screws.

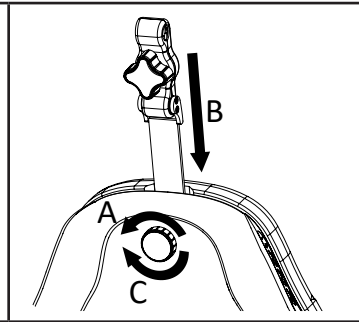

10. A. Loosen the knob on the back of the back section of the chair.
 B. Insert the headrest lock mechanism (or headrest cover assembly) into the slotted opening in the top of the backrest.
 C. Tighten the knob on the backrest.

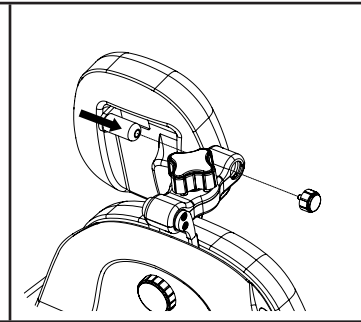

11. **461 Model Only:** Loosen the knob on the articulating headrest mechanism and rotate it forward as shown. Remove the knob on the back of the headrest. Insert the headrest into lock mechanism. Reinsert knob, position headrest as desired, and tighten both knobs.

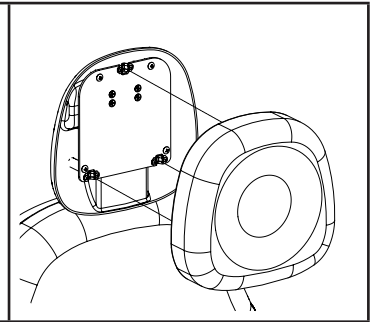

12. **403 Model Only:** Attach the headrest cushion to the headrest cover assembly by aligning the 3 ball studs with the (3) receptacles and pressing into place.

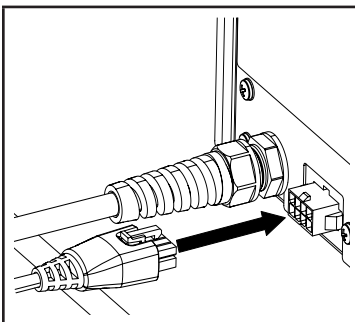

13. If applicable, plug in the foot control at the base of the chair.

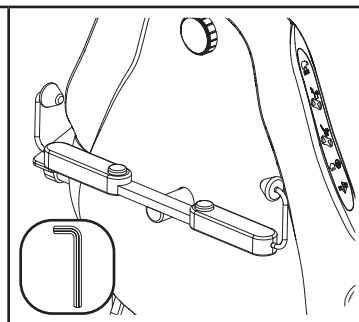

14. If applicable, attach any accessories. See the accessory's Instruction Guide for installation instructions.

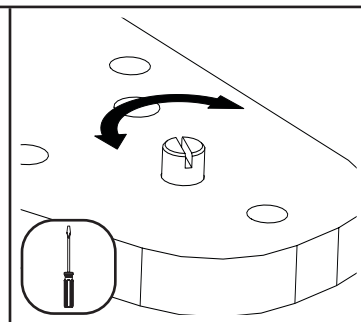

15. Position the chair in the desired location. Level the chair by adjusting the height of the individual leveling glides with a flat head screwdriver.

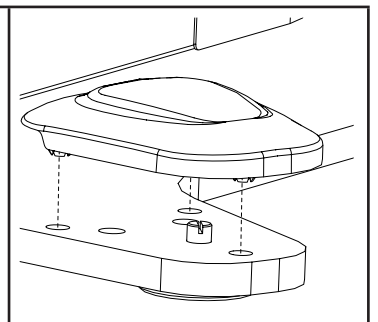

16. Install the (4) leveling glide covers over the feet of the baseplate. Align the snap features over the three holes and press down.

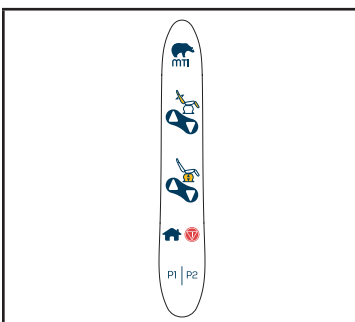

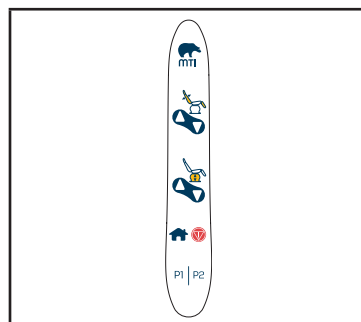

17. Verify all functions of the chair are operational.



18. Save Program Buttons' positions to desired locations. See "Controls" on page 15 for programming instructions.

OPERATION

Operating Conditions

| | | |
|---|----------------------|--|
|  | Ambient Temperature | +10°C to +40°C (+50°F to +104°F) |
|  | Relative Humidity | 30% to 75% (non-condensing) |
|  | Atmospheric Pressure | 700 hPa to 1060 hPa (0.69 atm to 1.05 atm) |

Maximum surface temperature of applied part chair surfaces will not exceed 42°C.

Soft Start and Stop Technology

The Soft Start and Stop Technology is the programming built into the chair that provides smoother deceleration and acceleration during the movement of the chair.

Program Positions

The controller technology allows users to save (2) positions. To save a position, press and hold the desired program button (P1 or P2) for 5 seconds. Once the position has been saved, the chair will beep twice to indicate the position has been saved successfully.

Any Button Cancellation Technology

The Any Button Cancellation Technology allows the user to cancel all motion of the chair by pressing any button except for the button that was pressed to initiate the movement.

Current Sensing Technology

Current Sensing Technology is the feature that is built into the chair that senses if the actuators in the chair are experiencing too much load and will automatically stop motion to prevent damage. Current sensing technology will also slow the motion of the chair when experiencing higher loads for increased stability.

Shutdown

To shutdown the 461/403 Exam Chair, unplug the chair from the outlet.

Controls

| ITEM | DESCRIPTION | FUNCTION |
|--|-------------------------------------|---|
| FOOT CONTROLS AND HAND SWITCHES | | |
| 1 | Back Up/Down Buttons | Raises or lowers the backrest in coordination with the leg rest by pressing the desired direction. |
| 2 | Lift Up/Down Buttons | Raises or lowers the chair top by pressing the desired direction. |
| 3 | Stop Button (Emergency Stop Button) | Stops all motorized movement of chair. |
| 4 | Home Button | The Home Button moves the chair to a comfortable seated position with the backrest at 80° and the seat at the lowest position for patient exit and entry. See Note 1 below. |
| 5 | Program Buttons (P1, P2,) | The Program Buttons move the chair to a user defined Program Position. NOTE: The chair has no pre-existing Program Positions upon arrival and will only beep and not move until Program Positions have been saved. See "Program Positions" on page 14 for instructions for saving a Program Position. |

Note 1: Press the Back Up Button to move the backrest further forward than the Home position. The backrest can be positioned up to 88° from horizontal.

NOTICE/AVIS

For additional safety, any button will stop all automatic motions except for the same button that was pressed to initiate movement.

Pour plus de sécurité, n'importe quel bouton peut arrêter tous les mouvements automatiques à l'exception du bouton même qui a été pressé de commencer le mouvement.

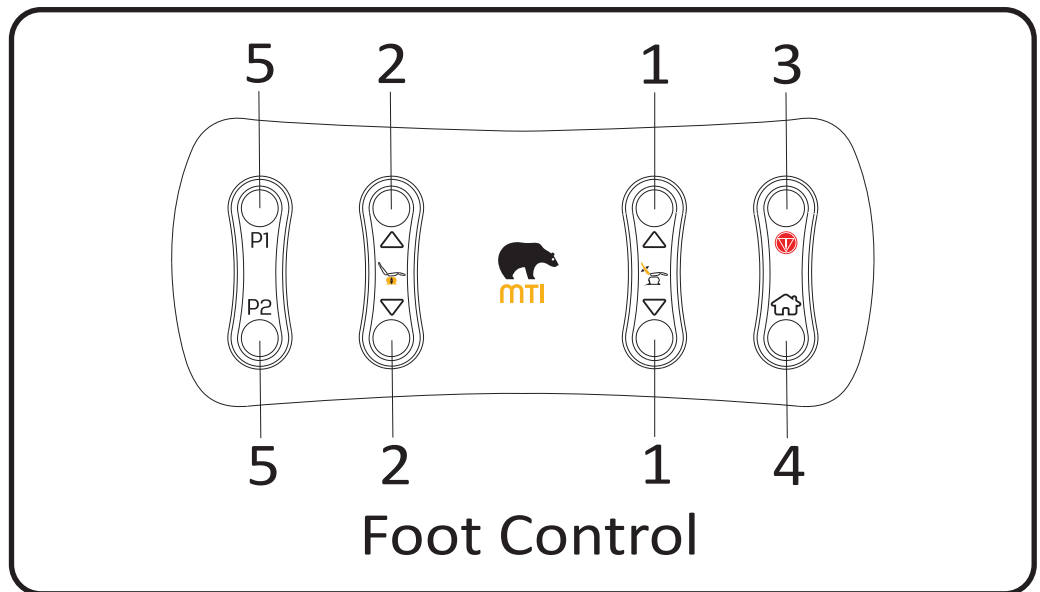
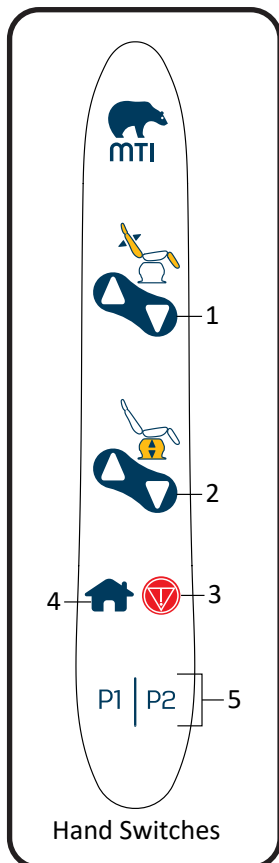

Headrest Operation

Articulating Headrests

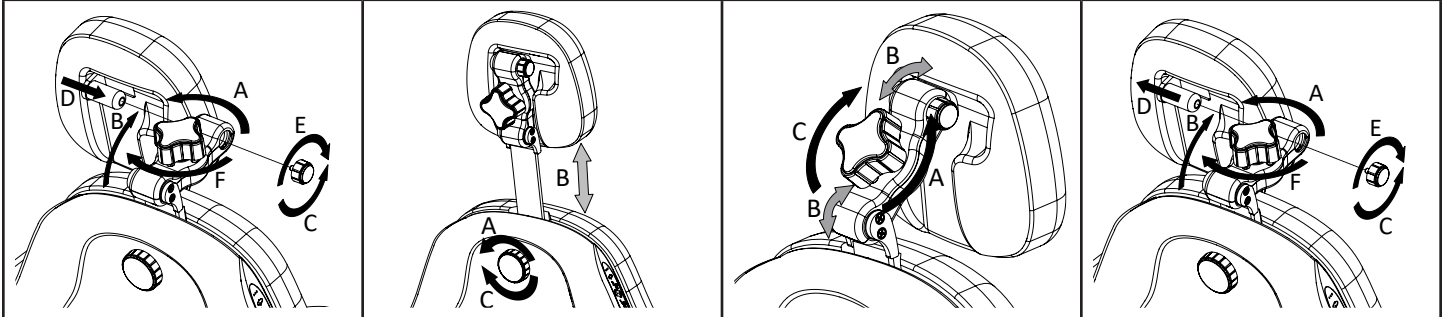

1. To attach the headrest.

- A. Loosen the knob on the articulating headrest lock mechanism.
- B. Rotate the articulating headrest lock mechanism forward.
- C. Remove the small knob on the headrest pintle (turn counterclockwise).
- D. Insert the headrest pintle into the articulating headrest lock mechanism.
- E. Reattach the small knob into the end of the headrest pintle (turn clockwise).
- F. Reposition the headrest to a desired location and tighten the knob on the articulating headrest mechanism.

2. To adjust the height of the headrest:

- A. To loosen, turn the knob on the back of the chair counterclockwise.
 - B. Adjust the height of the headrest.
 - C. To secure, turn the knob clockwise.
- The headrest can be completely removed, if desired, when the knob is loosened.

3. To adjust the angle of the headrest:

- A. To loosen, turn the knob on the articulating headrest lock mechanism counterclockwise.
- B. Adjust the position and angle of the headrest.
- C. To secure, turn the knob clockwise.

4. To remove a headrest:

- A. Loosen the knob on the articulating headrest lock mechanism.
- B. Rotate the articulating headrest lock mechanism forward.
- C. Remove the small knob on the headrest pintle (turn counterclockwise).
- D. Pull the headrest completely out of the headrest lock mechanism.
- E. Reattach the small knob to the end of the headrest pintle to keep it from being lost (turn clockwise).

Non-Articulating Headrests

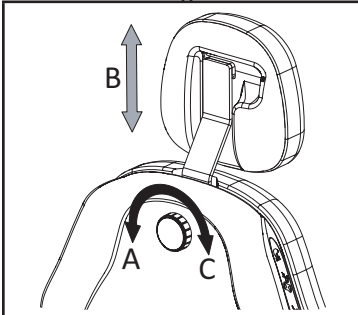

1. To adjust the height of the headrest:

- A. To loosen, turn the knob on the back of the chair counterclockwise.
- B. Adjust the height of the headrest.
- C. To secure, turn the knob clockwise.

The headrest can be completely removed, if desired, when the knob is loosened.

Armrest Operation

Flip-Up Floating Arms

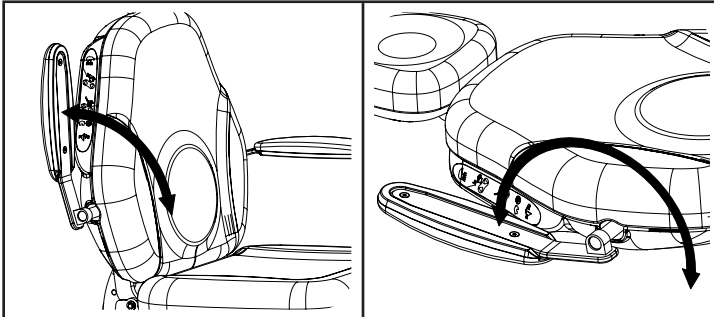

Each arm can be independently moved. When the chair is in the seated position, the arm can move upward until it is nearly vertical. When the backrest is completely lowered the arm can move from horizontally forward to horizontally backward.

To move an arm:

Lift up on the arm to move it out of the way.

Gently lower the arm to return it.

WARNING/AVERTISSEMENT

The arms do not lock in place. Use caution to prevent the arms from being bumped while in the upright position. Grasp arms securely while moving them to prevent them from falling rapidly.

Les accoudoirs ne se verrouille pas en place. Faites preuve de prudence pour éviter que les accoudoirs ne soient heurtés en position verticale. Tenir fermement les accoudoirs tout en les déplaçant pour les empêcher de tomber rapidement.

Footrest Operation (461 Model Only)

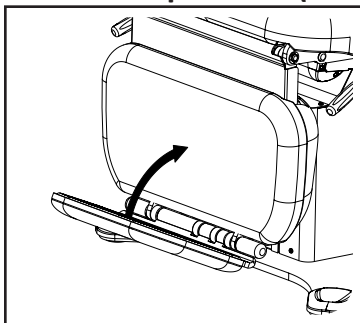

1. To fold up the footrest:

Lift up on the footrest until it magnetically latches to the leg rest cushion.

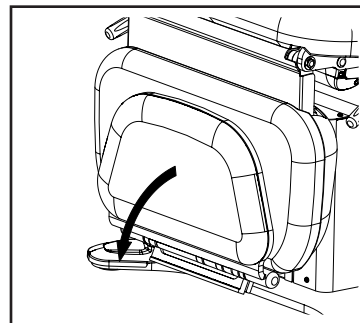

2. To fold the footrest down:

Pull the footrest away from the leg rest cushion and guide it down until it comes to a stop.

WARNING/AVERTISSEMENT

When the footrest is released from the upright position, ensure equipment, patient, and users are clear of its path to avoid harm.

Lorsque le repose-pied est libéré de la position verticale, assurez-vous que le matériel, le patient et les utilisateurs sont dégagés de son chemin pour éviter tout dommage.

Swivel Operation

To swivel the chair, release the swivel lock by lowering either handle on the side of the chair. Swivel the chair to the desired position. Secure the swivel lock by pulling up on either handle on the side of the chair.

WARNING/AVERTISSEMENT

Ensure the swivel is in the locked state before allowing a patient to enter or exit the equipment, or if the equipment needs to be relocated.

Assurer le pivot est verrouillé avant de permettre au patient d'entrer ou de sortir de l'équipement ou si l'équipement doit être déplacé.

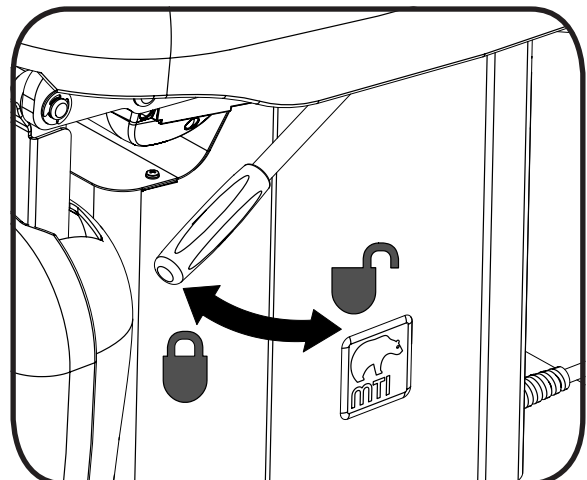

LIST OF ACCESSORIES

| DESCRIPTION | USE | RESTRICTIONS |
|--|--|---|
| Additional Headrests | | |
| 461: Deep Oval, Magnetic, and Prosthetic Articulating Headrests | Provides an articulating surface with various pillow shapes/sizes to support patient's head. | |
| 403: Oval, Deep Oval, Magnetic, and Prosthetic Articulating Headrests | Provides an articulating surface with various pillow shapes/sizes to support patient's head. | Requires Dual Articulating Headrest Mechanism |
| Lighting Options | | |
| Adptr Kit, Back Mtd Exam Light | Provides a mount on the back of the chair for 12-24V Lumerus Exam Light. | Not compatible with Paper Roll Holder. |
| Exam Light, Lumerus LED, Flex Neck, 12-24V DC | Provides lighting during patient procedures. | Requires Adptr Kit, Back Mtd Exam Light w/100-240V Transformer. |
| Other Accessories | | |
| Foot Control, 2 Func (L,B) w/8-Pin Plug G2 | Provides a foot control to manipulate the position of the chair. | |
| Leveling Glide Assy, 2" (set of 4) | Provides taller leveling glides than standard. | |
| Paper Roll Holder Assy, Adjustable 18" or 21" | Used for mounting a paper roll to the back of the chair. | Not compatible with a back mounted Exam Light. |

MAINTENANCE

WARNING/AVERTISSEMENT

There are no user serviceable parts inside. Refer all servicing to a qualified service technician.

Aucune pièce interne ne peut être réparée par l'utilisateur.

Adressez-vous à un technicien qualifié.

WARNING/AVERTISSEMENT

After equipment is serviced, verify programmable positions (P1-P2) are safe and known positions.

Après l'équipement est installé, vérifier les positions programmables (P1-P2) sont des positions sûres et connues.

WARNING/AVERTISSEMENT

The Control of Hazardous Energy (lockout/tagout) 29 CFR §1910.147 procedure must be followed to disable equipment, preventing the release of hazardous energy while performing servicing and maintenance activities.

La procédure de La Maîtrise des Énergies Dangereuses (lockout/déconsignation) 29 CFR §1910.147 doit être suivie pour désactiver l'équipement, empêchant la libération des énergies dangereuses lors de l'exécution des activités de maintenance et d'entretien.

WARNING/AVERTISSEMENT

MTI recommends cleaning the equipment frequently. Follow the current CDC Guideline for Disinfection & Sterilization in Healthcare Facilities or other local guidelines for disinfecting.

MTI recommande de nettoyer l'appareil fréquemment. Suivez les lignes directrices actuelles du CDC pour la désinfection et la stérilisation dans les établissements de santé ou d'autres directives locales pour la désinfection.

CAUTION/PRÉCAUTION

This equipment may be damaged by solvents and dyes. Immediately remove any fluids spilled on the equipment.

Cet équipement peut être endommagé par des solvants et des colorants. Retirer immédiatement tout liquide renversé sur l'équipement.

CAUTION/PRÉCAUTION

Contact with sharp or pointed objects can damage the upholstery. Do not place hard surface objects on the upholstery surfaces as temporary indentations or impressions in the upholstery cover will result. Prolonged contact with a hard

or irregular shaped object may make the impression semi-permanent.

Le contact avec des objets pointus ou tranchants peut endommager le capitonnage. Ne placez pas d'objets de surfaces dures sur les surfaces de capitonnage d'ameublement, comme des empreintes temporaires ou des impressions dans le couvercle du capitonnage en résulteront. Un contact prolongé avec un objet en forme de disque ou irrégulière peut faire l'impression semi-permanente.

CAUTION/PRÉCAUTION

Any sprayed disinfectant or cleaning solution should be wiped up immediately after application and not let to stand. A small sample area should be tested before any large application of any cleaner/disinfectant.

Tout désinfectant pulvérisé ou solution de nettoyage doivent être essuyés immédiatement après l'application et ne pas laisser reposer. Une petite zone de l'échantillon doit être testé avant toute application complète d'un nettoyant/désinfectant.

CAUTION/PRÉCAUTION

Avoid prolonged direct sunlight exposure to preclude decolorization.

Évitez l'exposition prolongée au soleil direct afin d'éviter la décoloration.

CAUTION/PRÉCAUTION

Replace damaged upholstery to prevent cross contamination.

Remplacer le capitonnage endommagé pour éviter la contamination croisée.

Disinfection

Follow the current CDC Guideline for Disinfection & Sterilization in Healthcare Facilities or other local guidelines.

Upholstery

MTI understands that many customers prefer to use a pre-mixed disinfecting solution in a spray or wipe. It is MTI's recommendation not to use sprays because over time the overspray will cause damage to the surfaces if not immediately wiped up. See "MTI Suggested Disinfectants Policy" for more details on disinfecting solutions which have been tested on MTI's products. It is available for download at www.mti.net/DisinfectantsPolicy. In the U.S. & Canada, call (877) 875-4990, or International call (801) 875-4990, or email technical.support@mti.net to request a copy.

Cleaning

Upholstery should be cleaned weekly with a mild liquid soap and water mixture. Afterwards, wipe upholstery with clean damp cloth.

Painted and Plastic Surfaces

All painted metal parts have been electrostatically painted and the paint is baked on for durability. Weekly, those surfaces should be wiped down with a quality grade cleaner and a soft cloth or a damp cloth with mild soap.

Preventative Maintenance

Periodically inspect the following areas:

1. All fasteners and pins should be in place and tightened securely.
2. Power cord should be free of cuts or other visible damage.
3. All mechanical functions should operate properly.

Have an authorized service technician inspect your equipment once a year.

Calls for Service

Equipment's model and serial number information are required when calling for service.

Serial number is indicated by the  symbol located on the serial number tag.

If service is required, contact MTI.

U.S. & Canada (877) 875-4990

International (801) 875-4990

Fax (801) 952-0548

technical.support@mti.net

www.mti.net



LIMITED WARRANTY

Medical Technology Industries, Inc. (hereinafter referred to as MTI), shall repair or replace products of its manufacture, which prove to be defective in material and/or workmanship for a period of twelve (12) months from the date of shipment to the customer (the "Warranty Period"). MTI will, at its option, provide parts to the customer or repair the defective part at MTI's factory or authorized repair facility. Except as it may otherwise specifically agree in writing, MTI shall not be liable for transportation or labor charges for repairs or adjustments or other work done on any of its products by MTI's authorized dealers or service organizations.

Customer shall notify MTI of any alleged claim or defect within fourteen (14) days from the date customer discovers, or upon reasonable inspection should have discovered, such alleged claim or defect (but in any event before the expiration of the Warranty Period). All repair parts are warranted for Ninety (90) calendar days from the date of shipment to the customer. Warranty is non-cumulative.

This warranty does not apply to any part or product which upon examination by MTI or its authorized agents indicates the product has been repaired or altered in any way by persons other than MTI or its authorized agents, has been misused, abused or used in a manner contrary to any instructions issued by MTI. Any parts or products claimed under this warranty must be properly packaged by customer and returned to MTI's factory with no liability to MTI for the parts, products or transportation charges thereon.

In no event, shall MTI have any liability for consequential, indirect, incidental, special, exemplary, punitive or enhanced damages, lost profits or diminution in value arising out of or relating to a product defect or the repair or replacement of any products manufactured or sold by it.

THE FOREGOING LIMITED WARRANTY IS MADE IN LIEU OF ALL WARRANTIES EXPRESSED OR IMPLIED, AND MTI MAKES NO OTHER WARRANTY WHATSOEVER WITH RESPECT TO THE PRODUCTS INCLUDING BUT NOT LIMITED TO, ANY IMPLIED WARRANTY OR MERCHANTABILITY OR FITNESS FOR A PARTICULAR PURPOSE.

TROUBLESHOOTING GUIDE

NOTICE/AVIS

See “SOUND GUIDE” on page 23 for additional solutions. For more information on this equipment, including circuit diagrams, parts and service manual (Item No. 130-3833), and other helpful information, please contact MTI.

Voir «SOUND GUIDE» à la page 23 pour des solutions supplémentaires. Pour plus d’informations sur cet équipement, y compris des schémas de circuits, le manuel de service et pièces (Numéro d’article 130-3833), et d’autres informations utiles, s’il vous plaît contacter MTI.

| # | SYMPTOMS | PROBLEM CAUSE | SOLUTION |
|---|---|--|--|
| 1 | Chair will not function. | Chair power cord is not securely connected. | Verify power cord is securely connected to an appropriate power outlet. |
| | | Facility power or receptacle problem. Facility power circuit breaker problem. | Check facility’s power receptacle with a known working device of same voltage specifications. Also check facility circuit breaker to verify it is not tripped if no power to known working device. |
| | | Facility supply voltage is incorrect voltage. | Verify voltage is per specifications on chair serial number/product tag. |
| | | Faulty hand switches | If possible, test a foot control from similar equipment. Otherwise, contact Technical Support. |
| | | Chair Controller isn’t functioning correctly. | Contact Technical Support. |
| 2 | Lift or Back functions will not function. | An actuator is experiencing excessive loads. | Remove or reposition patient to continue normal operation. |
| | | An actuator is not functioning or Chair Controller isn’t functioning correctly. | Contact Technical Support. |
| 3 | The chair does not move when a Program Button is pressed. | The Program Button does not have a saved location. | See “Controls” on page 15 for instructions on saving a Program Button location. |
| 4 | Chair will not function or a function is erratic. | Chair Controller isn’t functioning correctly. | Contact Technical Support. |
| 5 | Lift function is slower than usual with no patient in the chair or does not move. | The lifting column is not functioning or Chair Controller isn’t functioning correctly. | Contact Technical Support. |
| 6 | Swivel will not lock. | The swivel lock may require adjustment. | Contact Technical Support. |
| 7 | Motor is running after chair stops. | A motor gear has stripped. | Contact Technical Support for motor replacement. |

SOUND GUIDE

| # | SOUND | STATUS OR CONDITION |
|---|--|--|
| 1 | Short beep immediately after pressing P1 or P2 | Programmed position has not been saved. |
| 2 | Short beep and chair stops moving | Current sensing has detected an excessive load and stopped the actuator or column. Remove or reposition patient. |
| 3 | Double beep | A programmed position has been successfully saved. |
| 4 | Every button press results in a beep | Chair is not calibrated. Program Buttons and Home Button will not function. Contact Technical Support. |
| 5 | Short beep when chair is plugged in. | Indicates chair is powered up and ready for operation. |

SPECIFICATIONS

| DESCRIPTION | SPECIFICATION |
|---|---|
| Load Capacity ¹ Lift Back Footrest (Stationary Load) (461 Model Only) Looped Footrest (403 Model Only) | 550 lb (249 kg) 300 lb (136 kg) 150 lb (68 kg) 150 lb (68 kg) |
| Weight of Chair ² 461 Exam Chair 403 Exam Chair | 244 lb (111 kg) 216 lb (98 kg) |
| Shipping Weight of Chair ³ 461 Exam Chair 403 Exam Chair | 308 lb (140kg) 280 lb (127 kg) |
| Shipping Weight of Upholstery Kit 461 Seamless/Designer Upholstery Kit 403 Seamless/Designer Upholstery Kit | 24 lb (11 kg) 24 lb (11 kg) |
| Table Top Range 461/403 Exam Chair | 21-38 in (53.3-96.5 cm) |
| Back Section Range ⁴ | -5°± 2.2° to 88°± 2.2° |
| Foot Section Range ⁴ (461 Only) | -5° ± 2.2° to 90°± 2.2° |
| Swivel Range | 323° |
| Tilt | Fixed at 5° |
| Foot Control (optional accessory) | IPX6 Rated |
| General Dimensions (w/headrest) 461 Exam Chair 403 Exam Chair | 21 in (53.3 cm) wide x 77 in (195.6 cm) long 21 in (53.3 cm) wide x 61 in (154.9 cm) long |
| Power Cord | Plugs: U.S.A. standard 3 prong Hospital Grade |
| Electrical Ratings | 100-240VAC (47-63 Hz); 8 Amps |
| Duty Cycle | Intermittent Operation, 10% Duty Cycle Example: (1) minute on (9) minutes off |
| Classification | Class 1, Type B Applied Part, Ordinary Equipment, Intermittent Operation. Applied parts include: Back, Seat, Leg rest, and Footrest Upholstery, Arms, Headrest, and Footrest/Foot Loop. |
| Listing/Approvals | IEC 60601-1:2005 Ed.3+A1;A2 AAMI ES60601-1:2005+C1;A2:2010 CSA C22.2#60601-1:2014 Ed.3+A2 IEC 60601-1-2 ed.4.1 (2020-09) |

¹Load Capacity will vary depending on placement and distribution of load on the section of the chair.

²Weight may vary due to product variation.

³Weight may vary due to variation in weight of shipping materials.

⁴Angles are measured relative to floor.



In-service Checklist for G2 Products with SmartTech™

| Model Number | Description | Serial Number(s) |
|--------------|-------------|------------------|
| | | |

The following in-service needs to be performed on this MTI product:

- Saved (2) User Program Buttons (P1-P2)
Save by positioning chair to desired location, press and hold the desired program button for 5 seconds. Once saved, audible confirmation will be given.
- Reviewed Controls and Operation sections of the User Manual

If you would like to receive occasional emails regarding MTI promotions and product announcements, fill out the sales form at www.mti.net/contact-us.

THIS PAGE IS INTENTIONALLY BLANK

THIS PAGE IS INTENTIONALLY BLANK



**Specialized Equipment
for Speciality Healthcare**
Medical Technology Industries

MTI, Inc.
3655 W Ninigret Drive
Salt Lake City, Utah, 84104-6572
800-924-4655 • call/text 801-875-4999 • Fax 801-952-0548
www.mti.net

© MTI All rights reserved. MTI reserves the right to make any product changes without notice. The MTI brand and Bear logo design are registered trademarks of MTI, Inc. in the United States.